

Machines and Mechanisms

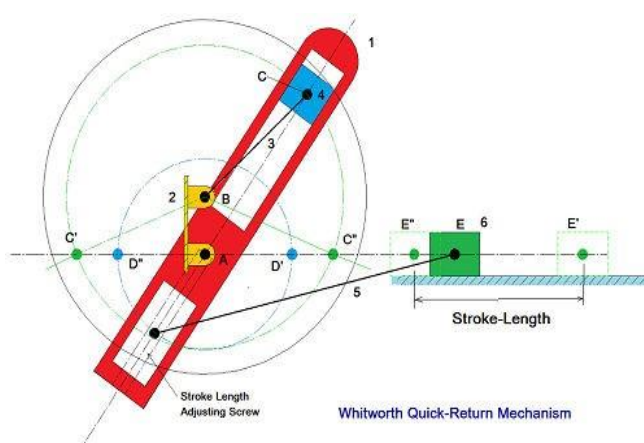

Course Contents

- 1.1 Machine and Mechanism
- 1.2 Types of constrained motion
- 1.3 Types of Link
- 1.4 Kinematic Pairs
- 1.5 Types of Joints
- 1.6 Degrees of Freedom
- 1.7 Kinematic Chain
- 1.8 Kutzbach Criterion
- 1.9 Grubler's criterion
- 1.10 The Four-Bar chain
- 1.11 Grashof's law
- 1.12 Inversion of Mechanism:
- 1.13 Inversion of Four-Bar chain
- 1.14 The slider-crank chain
- 1.15 Whitworth Quick-Return Mechanism:
- 1.16 Rotary engine
- 1.17 Oscillating cylinder engine
- 1.18 Crank and slotted-lever Mechanism
- 1.19 Examples based of D.O.F.

1.1 Machine and Mechanism:

➤ Mechanism:

- If a number of bodies are assembled in such a way that the motion of one causes constrained and predictable motion to the others, it is known as a *mechanism*.

➤ Machine:

- A *machine* is a mechanism or a combination of mechanisms which, apart from imparting definite motions to the parts, also transmits and modifies the available mechanical energy into some kind of desired work.

➤ Analysis:

- *Analysis* is the study of motions and forces concerning different parts of an existing mechanism.

➤ Synthesis:

- *Synthesis* involves the design of its different parts.

1.2 Types of constrained motion:

1.2.1 Completely constrained motion:

- When the motion between a pair is limited to a definite direction irrespective of the direction of force applied, then the motion is said to be a completely constrained motion.
- For example, the piston and cylinder (in a steam engine) form a pair and the motion of the piston is limited to a definite direction (*i.e.* it will only reciprocate) relative to the cylinder irrespective of the direction of motion of the crank.

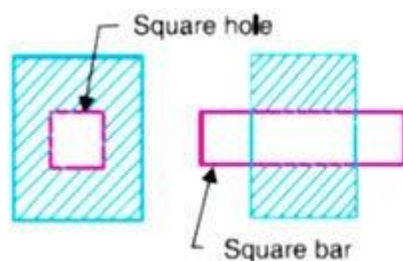

Fig. 1.1

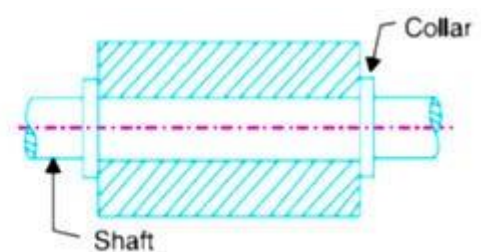

fig. 1.2

- The motion of a square bar in a square hole, as shown in Fig. 1.1, and the motion of a shaft with collars at each end in a circular hole, as shown in Fig. 1.2, are also examples of completely constrained motion.

1.2.2 Incompletely constrained motion:

- When the motion between a pair can take place in more than one direction, then the motion is called an incompletely constrained motion. The change in the direction of impressed force may alter the direction of relative motion between the pair. A circular bar or shaft in a circular hole, as shown in Fig. 1.3, is an

example of an incompletely constrained motion as it may either rotate or slide in a hole. These both motions have no relationship with the other.

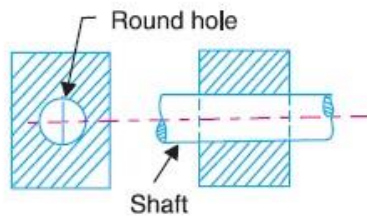

Fig. 1.3

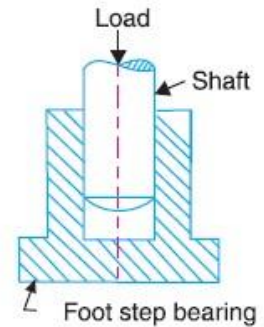

FIG. 1.4

1.2.3 Successfully constrained motion:

- When the motion between the elements, forming a pair, is such that the constrained motion is not completed by itself, but by some other means, then the motion is said to be successfully constrained motion. Consider a shaft in a foot-step bearing as shown in Fig. 1.4.
- The shaft may rotate in a bearing or it may move upwards. This is a case of incompletely constrained motion. But if the load is placed on the shaft to prevent axial upward movement of the shaft, then the motion of the pair is said to be successfully constrained motion. The motion of an I.C. engine

1.3 Types of Links:

- A mechanism is made of a number of resistant bodies out of which some may have motions relative to the others. A resistant body or a group of resistant bodies with rigid connections preventing their relative movements is known as a link.
- A link may also define as a member or a combination of members of a mechanism, connecting other members and having motion relative to them.
- Links may be classified into binary, ternary and quaternary.



Binary link

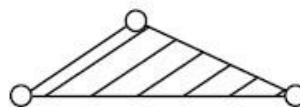

Ternary link

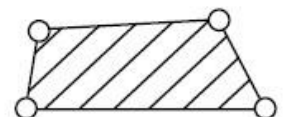

Quaternary link

FIG. 1.4 Types of link

1.4 Kinematic Pair:

- When two kinematic links are connected in such a way that their motion is either completely or successfully constrained, these two links are said to form a kinematic pair.
- Kinematic pairs can be classified according to:

1.4.1 Kinematic pairs according to nature of contact:

a. Lower Pair:

- A pair of links having surfaced or area contact between the members is known as a lower pair. The contact surfaces of two links are similar.
- Examples: Nut turning on a screw, shaft rotating in a bearing.

b. Higher Pair:

- When a pair has a point or line contact between the links, it is known as a higher pair. The contact surfaces of two links are similar.
- Example: Wheel rolling on a surface, Cam and Follower pair etc.

1.4.2 Kinematic pairs according to nature of contact:

a. Closed Pair:

- When the elements of a pair are held together mechanically, it is known as a closed pair. The two elements are geometrically identical; one is solid and full and the other is hollow or open. The latter not only envelops the former but also encloses it. The contact between the two can be broken only by destruction of at least one of the members.

b. Unclosed Pair:

- When two links of a pair are in contact either due to force of gravity or some spring action, they constitute an unclosed pair. In this, the links are not held together mechanically, e.g. cam and follower pair.

1.4.3 Kinematic pairs according to Nature of Relative Motion:

a. Sliding pair:

- When two links have a sliding motion relative to another; the kinematic pair is known as sliding pair.

b. Turning pair:

- When one link is revolve or turn with respect to the axis of first link, the kinematic pair formed by two links is known as turning pair.

c. Rolling pair:

- When the links of a pair have a rolling motion relative to each other, they form a rolling pair.

d. Screw pair:

- If two mating links have a turning as well as sliding motion between them, they form a screw pair.

e. Spherical pair:

- When one link in the form of sphere turns inside a fixed link, it is a spherical pair.

1.5 Types of Joint:

- The usual types of joints in a chain are:
 - Binary Joint
 - Ternary Joint
 - Quaternary Joint

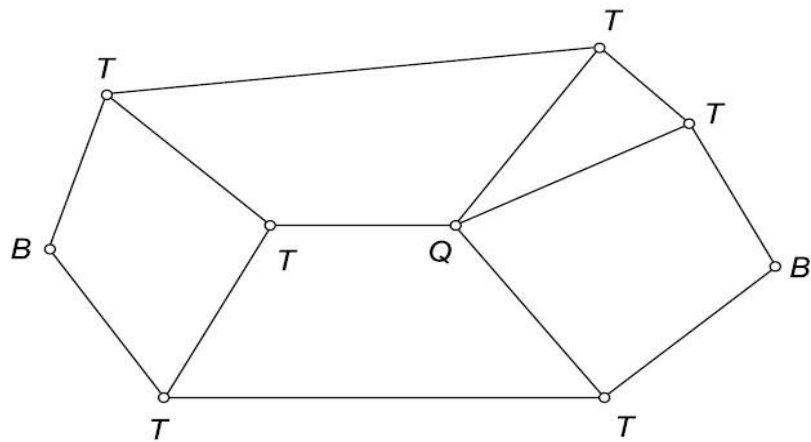

Fig1.5. Types of joint

a. Binary Joint:

- If two links are joined at the same connection, it is called a binary joint. For example, in fig. at joint B

b. Ternary Joint:

- If three links joined at a connection, it is known as a ternary link. For example point T in fig.

c. Quaternary Joint:

- If four links joined at a connection, it is known as a quaternary link. For example point Q in fig.

1.6 Degrees of Freedom:

- An unconstrained rigid body moving in space can describe the following independent motion:
 - Translational motion along any three mutually perpendicular axes x, y and z.
 - Rotational motion about these axes

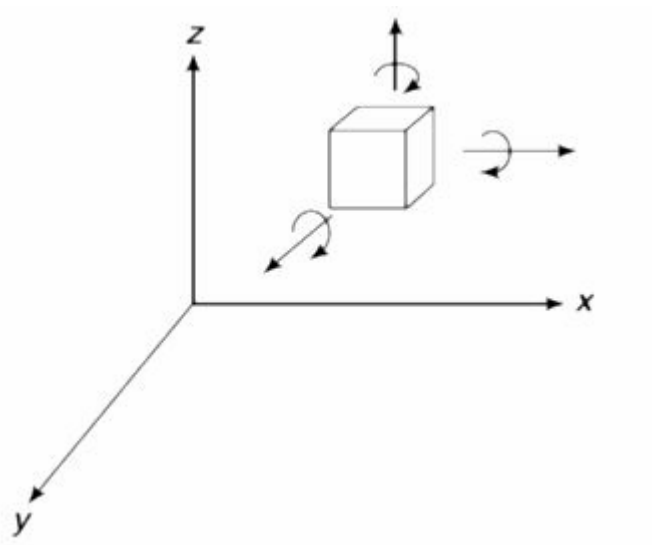

Fig.1.6 Degrees of freedom

- A rigid body possesses six degrees of freedom.

- Degrees of freedom of a pair is defined as the number of independent relative motions, both translational and rotational, a pair can have.
- $DOF = 6 - \text{Number of Restraints}$

1.7 Kinematic chain

- Kinematic chain is defined as the combination of kinematic pairs in which each link forms a part of two kinematic pairs and the relative motion between the links is either completely constrained or successfully constrained.
- Examples: slider-crank mechanism
- For a kinematic chain

$$N = 2P - 4 = 2(j + 2) / 3$$

- Where N = no. of links, P = no. of Pairs and j = no. of joints
- When,

LHS > RHS, then the chain is locked

LHS = RHS, then the chain is constrained

LHS < RHS, then the chain is unconstrained

1.8 Kutzbach Criterion

- DOF of a mechanism in space can be determined as follows:
- In mechanism one link should be fixed. Therefore total no. of movable links are in mechanism is $(N-1)$
- Any pair having 1 DOF will impose 5 restraints on the mechanism, which reduces its total degree of freedom by $5P_1$.
- Any pair having 2 DOF will impose 4 restraints on the mechanism, which reduces its total degree of freedom by $4P_2$
- Similarly, the other pairs having 3, 4 and 5 degrees of freedom reduce the degrees of freedom of mechanism. Thus,
- Thus,

$$F = 6(N-1) - 5P_1 - 4P_2 - 3P_3 - 2P_4 - 1P_5 - 0P_6$$

- Hence,

$$F = 6(N-1) - 5P_1 - 4P_2 - 3P_3 - 2P_4 - 1P_5$$

- The above equation is the general form of **Kutzbach criterion**. This is applicable to any type of mechanism including a spatial mechanism.

1.9 Grudler's Criterion

- If we apply the Kutzbach criterion to planer mechanism, then equation of Kutzbach will be modified and that modified equation is known as Grudler's Criterion for planer mechanism.
- Therefore in planer mechanism if we consider the links having 1 to 3 DOF, the total number of degree of freedom of the mechanism considering all restraints will become,

$$F = 3(N-1) - 2P_1 - 1P_2$$

- The above equation is known as **Grudler's Criterion** for planer mechanism.
- Sometimes all the above empirical relations can give incorrect results, e.g. fig (a) has 5 links, 6 turning pairs and 2 loops. Thus, it is a structure with zero degree of freedom.

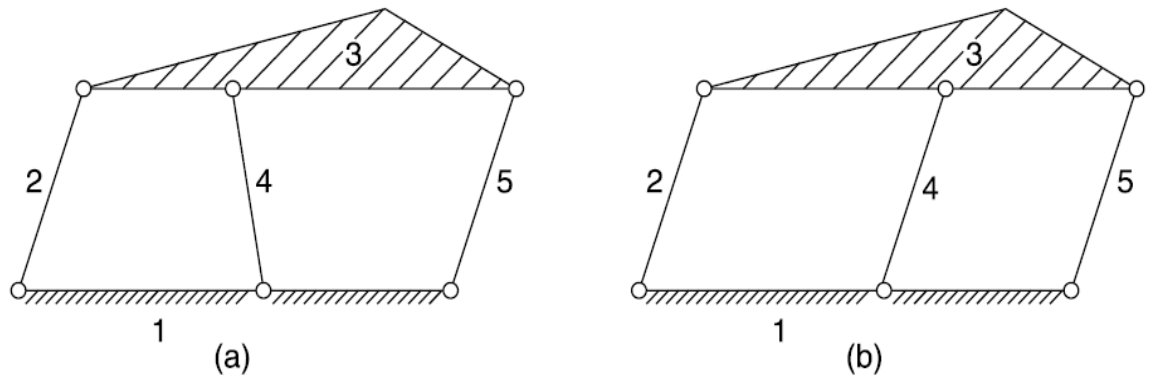

Fig. 1.7

- However, if the links are arranged in such a way as shown in fig. (b), a double parallelogram linkage with one degree of freedom is obtained. This is due to the reason that the lengths of links or other dimensional properties are not considered in these empirical relations.
- Sometimes a system may have one or more link which does not introduce any extra constraint. Such links are known as redundant links and should not be counted to find the degree of freedom. For example fig. (B) has 5 links, but the function of the mechanism is not affected even if any one of the links 2, 4 and 5 are removed. Thus, the effective number of links in this case is 4 with 4 turning pairs, and thus 1 degree of freedom.
- In case of a mechanism possessing some redundant degree of freedom, the effective degree of freedom is given by,

$$F = 3(N - 1) - 2P_1 - 1P_2 - F_r$$

- Where F_r = no. of redundant degrees of freedom

1.10 The Four-Bar chain

- A four bar chain is the most fundamental of the plane kinematic chains. It is a much proffered mechanical device for the mechanisation and control of motion due to its simplicity and versatility. Basically, it consists of four rigid links which are connected in the form of a quadrilateral by four pin-joints.
- When one of the link fixed, it is known as mechanism or linkage. A link that makes complete revolution is called the crank. The link opposite to the fixed link is called coupler, and the forth link is called a lever or rocker if it oscillates or another crank if it rotates.
- It is impossible to have a four-bar linkage if the length of one of the link is greater than the sum of other three. This has been shown in fig.

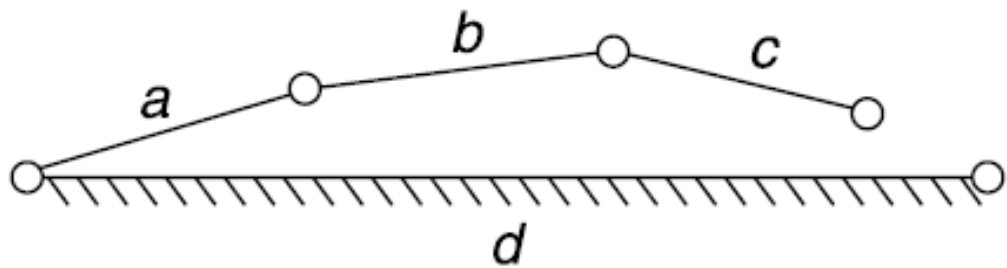

Fig. 1.7 Four bar chain

1.11 Grashof's law:

- We have already discussed that the kinematic chain is a combination of four or more kinematic pairs, such that the relative motion between the links or elements is completely constrained. The simplest and the basic kinematic chain is a four bar chain or quadric cycle chain, as shown in Fig. 5.18. It consists of four links, each of them forms a turning pair at A, B, C and D. The four links may be of different lengths.
- According to Grashof's law, the sum of the shortest and longest link lengths should not be greater than the sum of the remaining two link lengths if there is to be continuous relative motion between the two links.

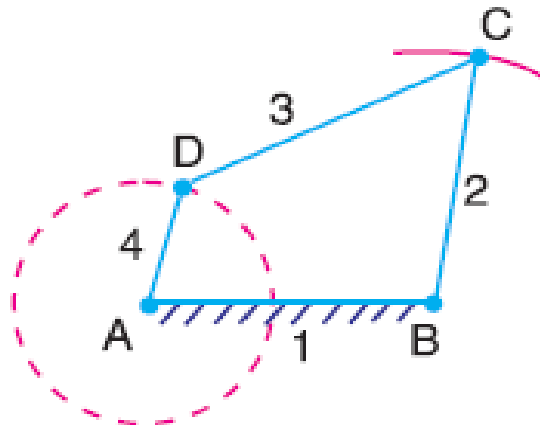

Fig. 1.8 Grashof's law

- A very important consideration in designing a mechanism is to ensure that the input crank makes a complete revolution relative to the other links. The mechanism in which no link makes a complete revolution will not be useful. In a four bar chain, one of the links, in particular the shortest link, will make a complete revolution relative to the other three links, if it satisfies the Grashof's law. Such a link is known as crank or driver. In Fig. 5.18, AD (link 4) is a crank.
- The link BC (link 2) which makes a partial rotation or oscillates is known as lever or rocker or follower and the link CD (link 3) which connects the crank and lever is called connecting rod or coupler. The fixed link AB (link 1) is known as frame of the mechanism.

1.12 Inversion of Mechanism:

- When the number of links in kinematic chain is more than three, the chain is known as mechanism. When one link of the kinematic chain at a time is fixed, give the different mechanism of the kinematic chain. The method of generating different mechanism by fixing a link is called the inversion of mechanism.
- The number of inversion is equal to the numbers of links in the kinematic chain.
- The inversion of mechanism may be classified as:
 - a. Inversion of four-bar chain
 - b. Inversion of single slider crank chain
 - c. Inversion of double slider crank chain

1.13 Inversion of Four-Bar chain

1.13.1 First inversion: coupled wheel of locomotive

- The mechanism of a coupling rod of a locomotive (also known as double crank mechanism) which consists of four links is shown in Fig.

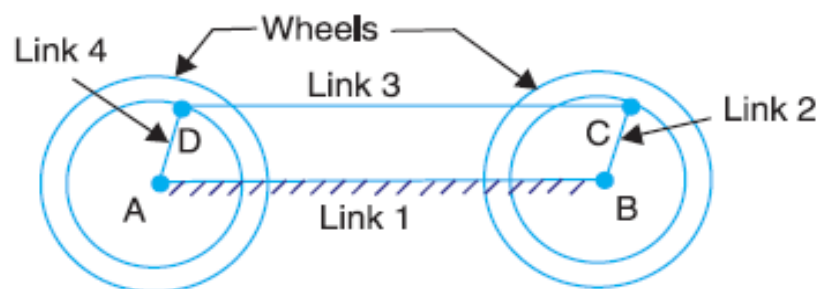

Fig. 1.9 coupled wheel of locomotive

- In this mechanism, the links AD and BC (having equal length) act as cranks and are connected to the respective wheels. The link CD acts as a coupling rod and the link AB is fixed in order to maintain a constant centre to Centre distance between them. This mechanism is meant for transmitting rotary motion from one wheel to the other wheel.

1.13.2 Second inversion: Beam Engine

- A part of the mechanism of a beam engine (also known as cranks and lever mechanism) which consists of four links is shown in Fig. 1.10.
- In this mechanism, when the crank rotates about the fixed centre A , the lever oscillates about a fixed centre D . The end E of the lever CDE is connected to a piston rod which reciprocates due to the rotation of the crank.

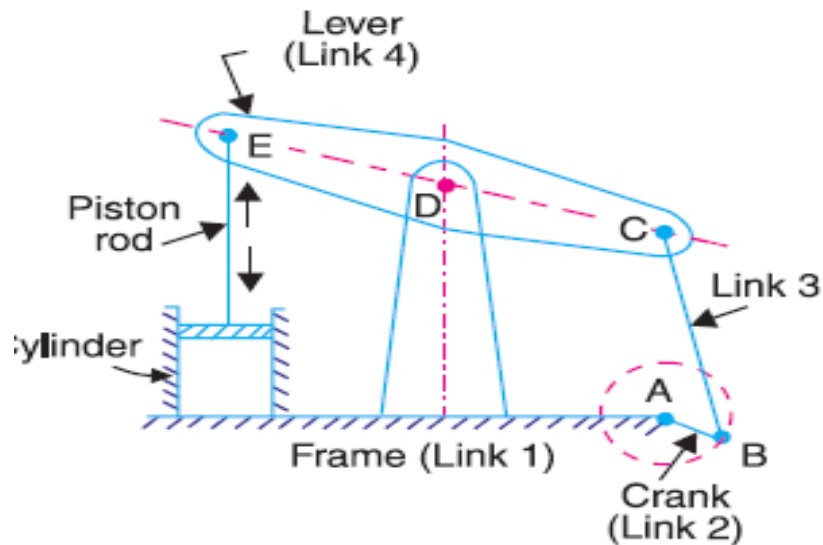

Fig. 1.10 beam engine

- In other words, the purpose of this mechanism is to convert rotary motion into reciprocating motion.

1.13.3 Third inversion: watts indicator mechanism

- A Watt's indicator mechanism (also known as Watt's straight line or double lever mechanism) which consists of four links is shown in Fig.
- The four links are: fixed link at A, link AC, link CE and link BFD. It may be noted that BF and FD form one link because these two parts have no relative motion between them. The links CE and BFD act as levers.
- The displacement of the link BFD is directly proportional to the pressure of gas or steam which acts on the indicator plunger. On any small displacement of the mechanism, the tracing point E at the end of the link CE traces out approximately a straight line.

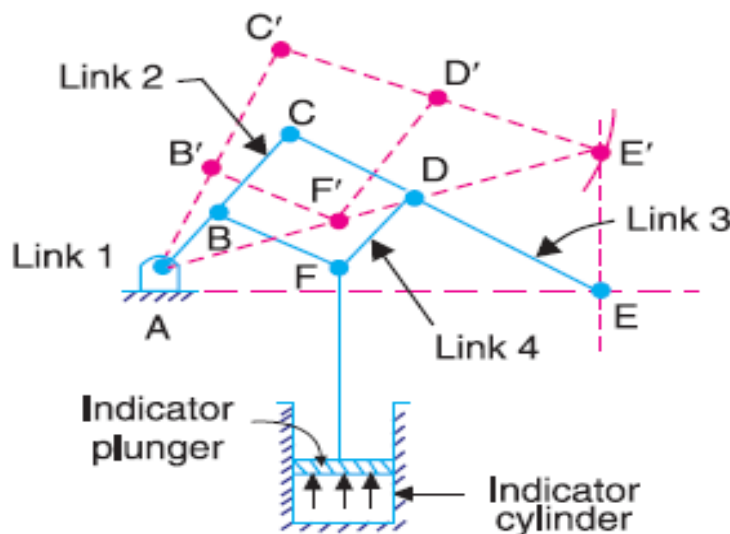

Fig. 1.11 watts indicator mechanism

1.14 The slider-crank chain

- When one of the turning pairs of a four-bar chain is replaced by a sliding pair, it becomes a single slider-crank chain or simply a slider-crank chain.
- It is also possible to replace two sliding pairs of a four-bar chain to get a double slider-crank chain. In a slider-crank chain, the straight line path of the slider may be passing through the fixed pivot O or may be displaced.
- The distance e between the fixed pivot O and the straight line path of the slider is called the offset and the chain so formed an offset slider-crank chain.
- Different mechanisms obtained by fixing different links of a kinematic chain are known as its inversions.

1.14.1 First inversion

- This inversion is obtained when link 1 is fixed and links 2 and 4 are made the crank and slider respectively. (fig.a)
- **Applications:**
 - a Reciprocating engine
 - b Reciprocating compressor

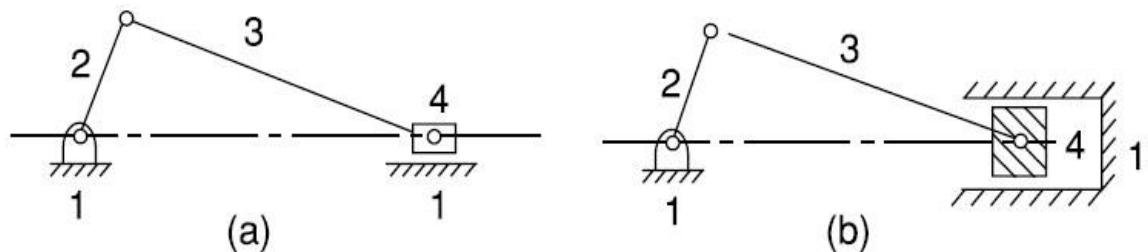

Fig. 1.12 first inversion

1.14.2 Second inversion

- Fixing of the link 2 of a slider-crank chain results in the second inversion.
- **Applications:**
 - a Whitworth quick-return mechanism
 - b Rotary engine

1.14.3 Third Inversion

- By Fixing of the link 3 of the slider-crank mechanism, the third inversion is obtained. Now the link 2 again acts as a crank and the link 4 oscillates.
- **Applications:**
 - a Oscillating cylinder engine
 - b Crank and slotted-lever mechanism

1.14.4 Fourth Inversion

- If the link 4 of the slider-crank mechanism is fixed, the fourth inversion is obtained. Link 3 can oscillates about the fixed pivot B on the link 4. This makes

the end A of the link 2 to oscillate about B and the end O to reciprocate along the axis of the fixed link 4.

– **Application: Hand Pump**

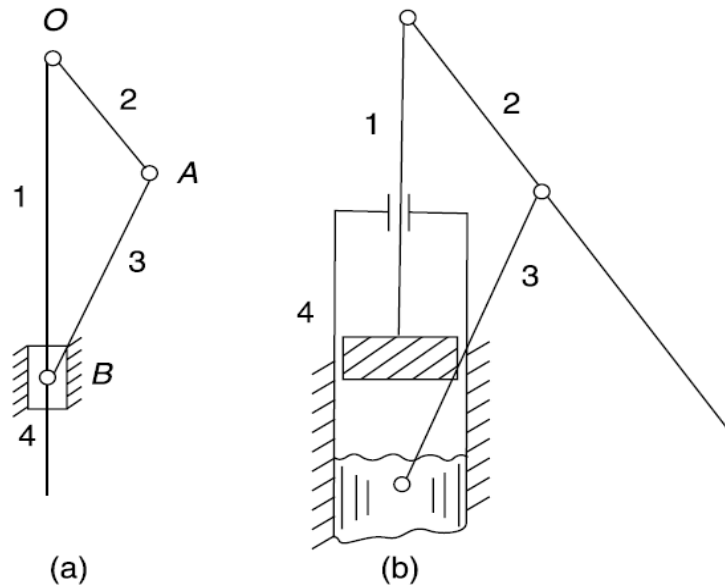

Fig. 1.13 hand pump

- Fig.1.13 shows a hand-pump. Link 4 is made in the form of a cylinder and a plunger fixed to the link 1 reciprocates in it.

1.15 Whitworth Quick-Return Mechanism:

- This mechanism used in shaping and slotting machines.
- In this mechanism the link CD (link 2) forming the turning pair is fixed; the driving crank CA (link 3) rotates at a uniform angular speed and the slider (link 4) attached to the crank pin at a slides along the slotted bar PA (link 1) which oscillates at D.
- The connecting rod PR carries the ram at R to which a cutting tool is fixed and the motion of the tool is constrained along the line RD produced.

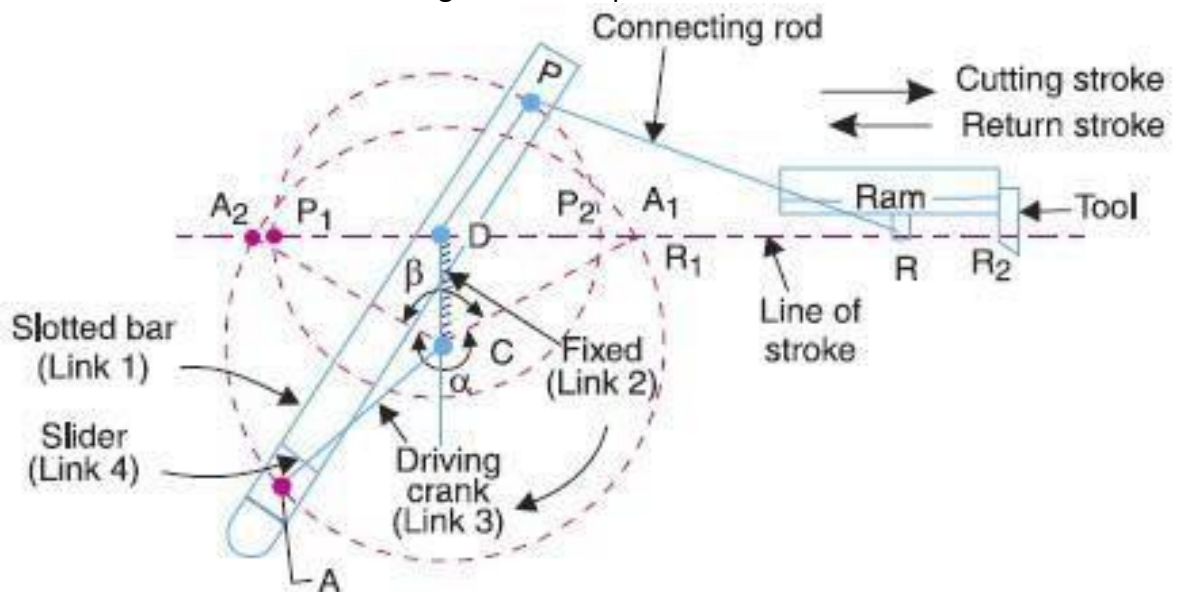

Fig. 1.14 Whitworth quick returns mechanism

- The length of effective stroke = 2 PD. And mark P1R1 = P2 R2 = PR.

$$\frac{\text{Time of cutting}}{\text{time of return}} = \frac{\alpha}{\beta} = \frac{\alpha}{360^\circ - \alpha} = \frac{360^\circ - \beta}{\beta}$$

1.16 Rotary engine

- Sometimes back, rotary internal combustion engines were used in aviation. But now-a-days gas turbines are used in its place.

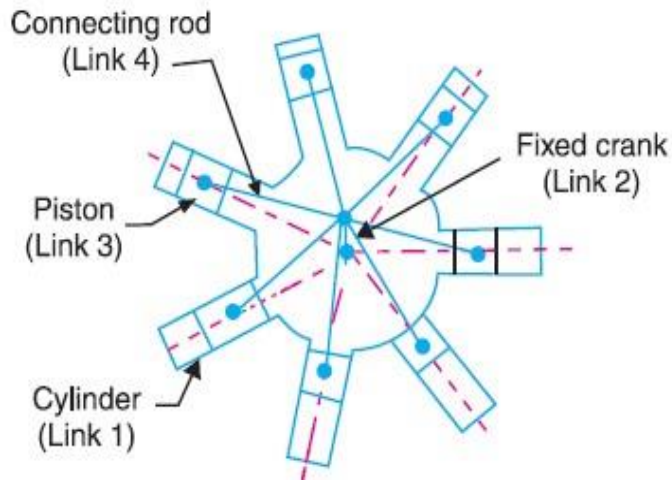

Fig. 1.15 rotary engine

- It consists of seven cylinders in one plane and all revolves about fixed center D, as shown in Fig. 5.25, while the crank (link 2) is fixed. In this mechanism, when the connecting rod (link 4) rotates, the piston (link 3) reciprocates inside the cylinders forming link 1.

1.17 Oscillating cylinder engine

- The arrangement of oscillating cylinder engine mechanism, as shown in Fig. Is used to convert reciprocating motion into rotary motion.

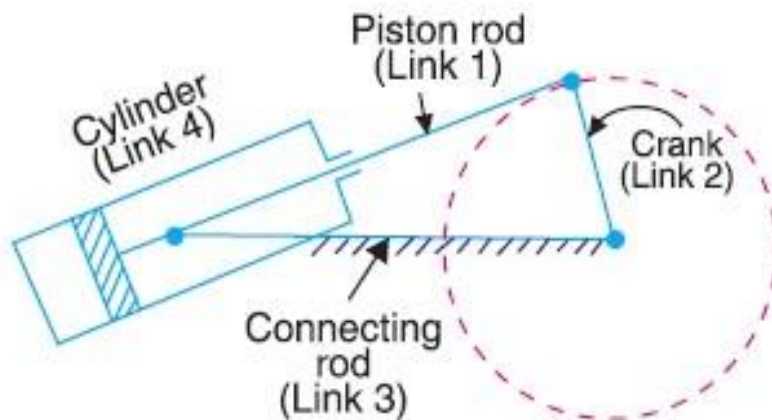

Fig. 1.16 oscillating cylinder engine

- In this mechanism, the link 3 forming the turning pair is fixed. The link 3 corresponds to the connecting rod of a reciprocating steam engine mechanism. When the crank (link 2) rotates, the piston attached to piston rod (link 1) reciprocates and the cylinder (link 4) oscillates about a pin pivoted to the fixed link at A.

1.18 Crank and slotted-lever Mechanism

- This mechanism is mostly used in shaping machines, slotting machines and in rotary internal combustion engines.
- In this mechanism, the link AC (i.e. link 3) forming the turning pair is fixed, as shown in Fig. The link 3 corresponds to the connecting rod of a reciprocating steam engine. The driving crank CB revolves with uniform angular speed about the fixed center C. A sliding block attached to the crank pin at B slides along the slotted bar AP and thus causes AP to oscillate about the pivoted point A.
- A short link PR transmits the motion from AP to the ram which carries the tool and reciprocates along the line of stroke R1R2. The line of stroke of the ram (i.e. R1R2) is perpendicular to AC produced.

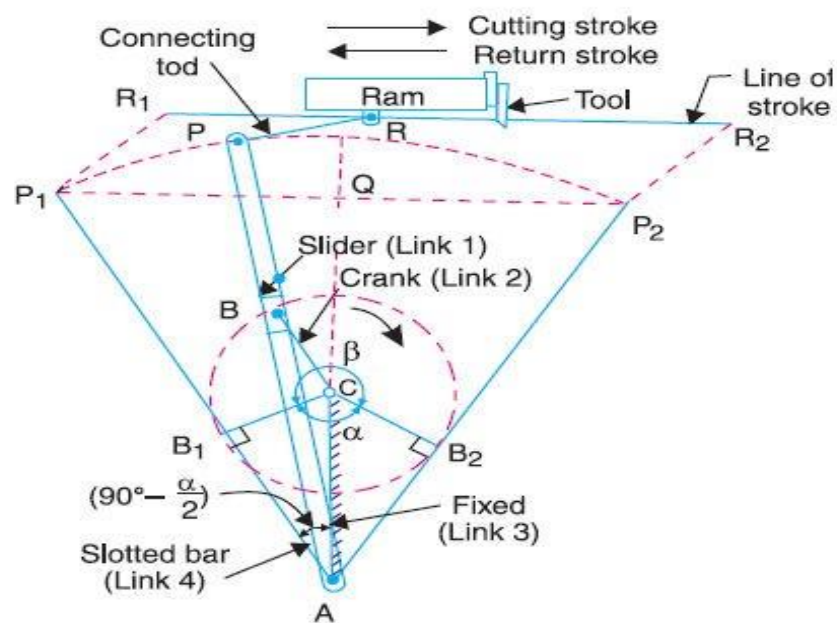

Fig.1.17 Crank and slotted lever mechanism

- In the extreme positions, AP1 and AP2 are tangential to the circle and the cutting tool is at the end of the stroke. The forward or cutting stroke occurs when the crank rotates from the position CB1 to CB2 through an angle β in the clockwise direction. The return stroke occurs when the crank rotates from the position CB2 to CB1 through an angle α in the clockwise direction. Since the crank has uniform angular speed, therefore,

$$\frac{\text{Time of cutting}}{\text{time of return}} = \frac{\beta}{\alpha} = \frac{\beta}{360^\circ - \beta} = \frac{360^\circ - \alpha}{\alpha}$$

1.19 Example based on Degrees of Freedom:

1 For the kinematic linkages shown in following fig. calculate the following:

The numbers of binary links (N_b)

The numbers of ternary links (N_t)

The numbers of other (quaternary) links (N_o)

The numbers of total links (n)

The numbers of loops (L)

The numbers of joints or pairs (P_1)

The numbers of degrees of freedom (F)

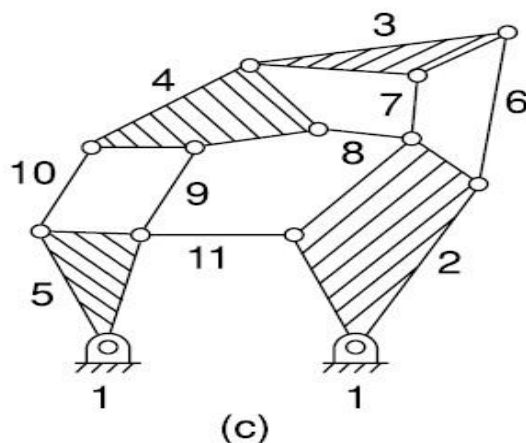
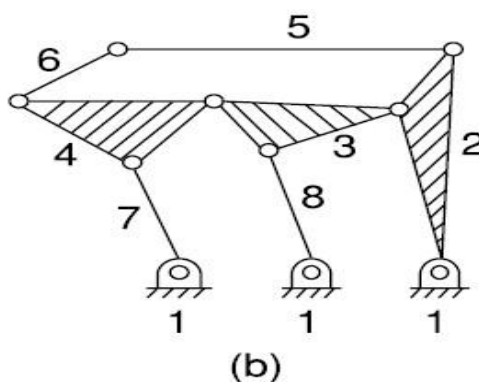
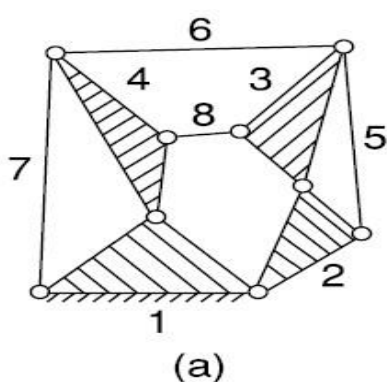

a $N_b = 4$; $N_t = 4$; $N_o = 0$; $N = 8$; $L = 4$; $P_1 = 11$ (by counting)

$$P_1 = (N + L - 1) = 11$$

$$F = 3(N - 1) - 2P_1$$

$$F = 3(8 - 1) - 2 \times 11 = -1 \text{ or, } v$$

$$F = N - (2L + 1)$$

$$F = 8 - (2 \times 4 + 1) = -1$$

b $N_b = 4$; $N_t = 4$; $N_o = 0$; $N = 8$; $L = 3$; $P_1 = 10$ (by counting)

$$P_1 = (N + L - 1) = 10$$

$$F = 3(N - 1) - 2P_1$$

$$F = 3(8 - 1) - 2 \times 10 = 1 \text{ or,}$$

$$F = N - (2L + 1)$$

$$F = 8 - (2 \times 3 + 1) = 1$$

C $N_b = 7$; $N_t = 2$; $N_0 = 2$; $N = 11$; $L = 5$; $P_1 = 15$ (by counting)

$$F = N - (2L + 1)$$

$$F = 11 - (2 \times 5 + 1) = 0$$

Therefore the linkage is a structure.

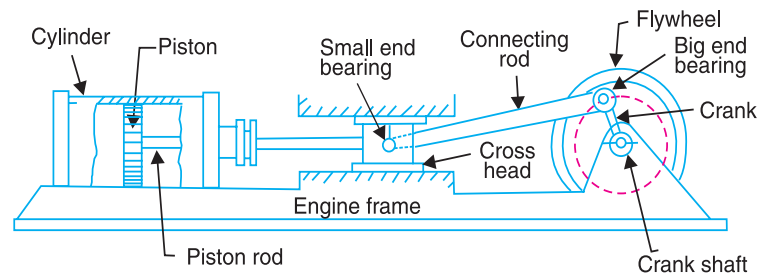

Fig. 5.1. Reciprocating steam engine.

A link or element need not to be a rigid body, but it must be a **resistant body**. A body is said to be a resistant body if it is capable of transmitting the required forces with negligible deformation. Thus a link should have the following two characteristics:

1. It should have relative motion, and
2. It must be a resistant body.



Piston and piston rod of an IC engine.

5.3. Types of Links

In order to transmit motion, the driver and the follower may be connected by the following three types of links :

1. Rigid link. A rigid link is one which does not undergo any deformation while transmitting motion. Strictly speaking, rigid links do not exist. However, as the deformation of a connecting rod, crank etc. of a reciprocating steam engine is not appreciable, they can be considered as rigid links.

2. Flexible link. A flexible link is one which is partly deformed in a manner not to affect the transmission of motion. For example, belts, ropes, chains and wires are flexible links and transmit tensile forces only.

3. Fluid link. A fluid link is one which is formed by having a fluid in a receptacle and the motion is transmitted through the fluid by pressure or compression only, as in the case of hydraulic presses, jacks and brakes.

5.4. Structure

It is an assemblage of a number of resistant bodies (known as members) having no relative motion between them and meant for carrying loads having straining action. A railway bridge, a roof truss, machine frames etc., are the examples of a structure.

5.5. Difference Between a Machine and a Structure

The following differences between a machine and a structure are important from the subject point of view :

1. The parts of a machine move relative to one another, whereas the members of a structure do not move relative to one another.
2. A machine transforms the available energy into some useful work, whereas in a structure no energy is transformed into useful work.
3. The links of a machine may transmit both power and motion, while the members of a structure transmit forces only.

5.6. Kinematic Pair

The two links or elements of a machine, when in contact with each other, are said to form a pair. If the relative motion between them is completely or successfully constrained (*i.e.* in a definite direction), the pair is known as **kinematic pair**.

First of all, let us discuss the various types of constrained motions.

5.7. Types of Constrained Motions

Following are the three types of constrained motions :

1. Completely constrained motion. When the motion between a pair is limited to a definite direction irrespective of the direction of force applied, then the motion is said to be a completely constrained motion. For example, the piston and cylinder (in a steam engine) form a pair and the motion of the piston is limited to a definite direction (*i.e.* it will only reciprocate) relative to the cylinder irrespective of the direction of motion of the crank, as shown in Fig. 5.1.

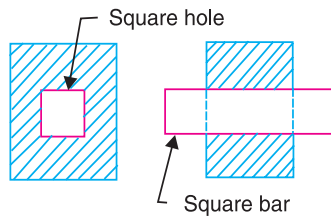

Fig. 5.2. Square bar in a square hole.

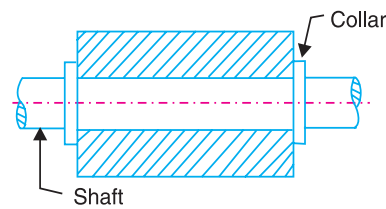

Fig. 5.3. Shaft with collars in a circular hole.

The motion of a square bar in a square hole, as shown in Fig. 5.2, and the motion of a shaft with collars at each end in a circular hole, as shown in Fig. 5.3, are also examples of completely constrained motion.

2. Incompletely constrained motion. When the motion between a pair can take place in more than one direction, then the motion is called an incompletely constrained motion. The change in the direction of impressed force may alter the direction of relative motion between the pair. A circular bar or shaft in a circular hole, as shown in Fig. 5.4, is an example of an incompletely constrained motion as it may either rotate or slide in a hole. These both motions have no relationship with the other.

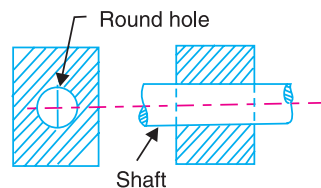

Fig. 5.4. Shaft in a circular hole.

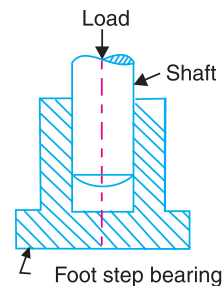

Fig. 5.5. Shaft in a foot step bearing.

3. Successfully constrained motion. When the motion between the elements, forming a pair, is such that the constrained motion is not completed by itself, but by some other means, then the motion is said to be successfully constrained motion. Consider a shaft in a foot-step bearing as shown in Fig. 5.5. The shaft may rotate in a bearing or it may move upwards. This is a case of incompletely constrained motion. But if the load is placed on the shaft to prevent axial upward movement of the shaft, then the motion of the pair is said to be successfully constrained motion. The motion of an I.C. engine

valve (these are kept on their seat by a spring) and the piston reciprocating inside an engine cylinder are also the examples of successfully constrained motion.

5.8. Classification of Kinematic Pairs

The kinematic pairs may be classified according to the following considerations :

1. According to the type of relative motion between the elements. The kinematic pairs according to type of relative motion between the elements may be classified as discussed below:

(a) Sliding pair. When the two elements of a pair are connected in such a way that one can only slide relative to the other, the pair is known as a sliding pair. The piston and cylinder, cross-head and guides of a reciprocating steam engine, ram and its guides in shaper, tail stock on the lathe bed etc. are the examples of a sliding pair. A little consideration will show, that a sliding pair has a completely constrained motion.

(b) Turning pair. When the two elements of a pair are connected in such a way that one can only turn or revolve about a fixed axis of another link, the pair is known as turning pair. A shaft with collars at both ends fitted into a circular hole, the crankshaft in a journal bearing in an engine, lathe spindle supported in head stock, cycle wheels turning over their axles etc. are the examples of a turning pair. A turning pair also has a completely constrained motion.

(c) Rolling pair. When the two elements of a pair are connected in such a way that one rolls over another fixed link, the pair is known as rolling pair. Ball and roller bearings are examples of rolling pair.

(d) Screw pair. When the two elements of a pair are connected in such a way that one element can turn about the other by screw threads, the pair is known as screw pair. The lead screw of a lathe with nut, and bolt with a nut are examples of a screw pair.

(e) Spherical pair. When the two elements of a pair are connected in such a way that one element (with spherical shape) turns or swivels about the other fixed element, the pair formed is called a spherical pair. The ball and socket joint, attachment of a car mirror, pen stand etc., are the examples of a spherical pair.

2. According to the type of contact between the elements. The kinematic pairs according to the type of contact between the elements may be classified as discussed below :

(a) Lower pair. When the two elements of a pair have a surface contact when relative motion takes place and the surface of one element slides over the surface of the other, the pair formed is known as lower pair. It will be seen that sliding pairs, turning pairs and screw pairs form lower pairs.

(b) Higher pair. When the two elements of a pair have a line or point contact when relative motion takes place and the motion between the two elements is partly turning and partly sliding, then the pair is known as higher pair. A pair of friction discs, toothed gearing, belt and rope drives, ball and roller bearings and cam and follower are the examples of higher pairs.

3. According to the type of closure. The kinematic pairs according to the type of closure between the elements may be classified as discussed below :

(a) Self closed pair. When the two elements of a pair are connected together mechanically in such a way that only required kind of relative motion occurs, it is then known as self closed pair. The lower pairs are self closed pair.

(b) Force - closed pair. When the two elements of a pair are not connected mechanically but are kept in contact by the action of external forces, the pair is said to be a force-closed pair. The cam and follower is an example of force closed pair, as it is kept in contact by the forces exerted by spring and gravity.

5.9. Kinematic Chain

When the kinematic pairs are coupled in such a way that the last link is joined to the first link to transmit definite motion (*i.e.* completely or successfully constrained motion), it is called a **kinematic chain**. In other words, a kinematic chain may be defined as a combination of kinematic pairs, joined in such a way that each link forms a part of two pairs and the relative motion between the links or elements is completely or successfully constrained. For example, the crankshaft of an engine forms a kinematic pair with the bearings which are fixed in a pair, the connecting rod with the crank forms a second kinematic pair, the piston with the connecting rod forms a third pair and the piston with the cylinder forms a fourth pair. The total combination of these links is a kinematic chain.



Lawn-mover is a combination of kinematic links.

If each link is assumed to form two pairs with two adjacent links, then the relation between the number of pairs (p) forming a kinematic chain and the number of links (l) may be expressed in the form of an equation :

$$l = 2p - 4 \quad \dots (i)$$

Since in a kinematic chain each link forms a part of two pairs, therefore there will be as many links as the number of pairs.

Another relation between the number of links (l) and the number of joints (j) which constitute a kinematic chain is given by the expression :

$$j = \frac{3}{2}l - 2 \quad \dots (ii)$$

The equations (i) and (ii) are applicable only to kinematic chains, in which lower pairs are used. These equations may also be applied to kinematic chains, in which higher pairs are used. In that case each higher pair may be taken as equivalent to two lower pairs with an additional element or link.

Let us apply the above equations to the following cases to determine whether each of them is a kinematic chain or not.

1. Consider the arrangement of three links AB , BC and CA with pin joints at A , B and C as shown in Fig. 5.6. In this case,

Number of links,	$l = 3$
Number of pairs,	$p = 3$
and number of joints,	$j = 3$
From equation (i),	$l = 2p - 4$
or	$3 = 2 \times 3 - 4 = 2$
<i>i.e.</i>	L.H.S. > R.H.S.

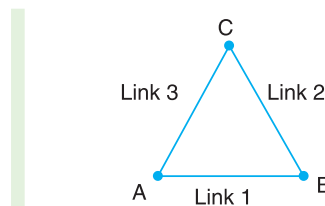

Fig. 5.6. Arrangement of three links.

Now from equation (ii),

$$2 \quad \text{or} \quad 3 \times \frac{3}{2} - 2 = 2.5$$

i.e.

$$\text{L.H.S.} > \text{R.H.S.}$$

Since the arrangement of three links, as shown in Fig. 5.6, does not satisfy the equations (i) and (ii) and the left hand side is greater than the right hand side, therefore it is not a kinematic chain and hence no relative motion is possible. Such type of chain is called **locked chain** and forms a rigid frame or structure which is used in bridges and trusses.

2. Consider the arrangement of four links AB , BC , CD and DA as shown in Fig. 5.7. In this case

$$l = 4, p = 4, \text{ and } j = 4$$

From equation (i),

$$l = 2p - 4$$

$$4 = 2 \times 4 - 4 = 4$$

i.e.

$$\text{L.H.S.} = \text{R.H.S.}$$

From equation (ii),

$$j = \frac{3}{2}l - 2$$

$$4 = \frac{3}{2} \times 4 - 2 = 4$$

i.e.

$$\text{L.H.S.} = \text{R.H.S.}$$

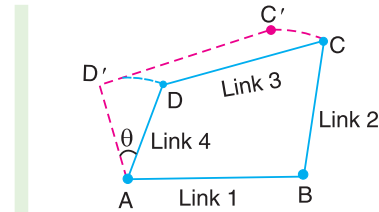

Fig. 5.7. Arrangement of four links.

Since the arrangement of four links, as shown in Fig. 5.7, satisfy the equations (i) and (ii), therefore it is a **kinematic chain of one degree of freedom**.

A chain in which a single link such as AD in Fig. 5.7 is sufficient to define the position of all other links, it is then called a kinematic chain of one degree of freedom.

A little consideration will show that in Fig. 5.7, if a definite displacement (say θ) is given to the link AD , keeping the link AB fixed, then the resulting displacements of the remaining two links BC and CD are also perfectly definite. Thus we see that in a four bar chain, the relative motion is completely constrained. Hence it may be called as a **constrained kinematic chain**, and it is the basis of all machines.

3. Consider an arrangement of five links, as shown in Fig. 5.8. In this case,

$$l = 5, p = 5, \text{ and } j = 5$$

From equation (i),

$$l = 2p - 4 \quad \text{or} \quad 5 = 2 \times 5 - 4 = 6$$

i.e.

$$\text{L.H.S.} < \text{R.H.S.}$$

From equation (ii),

$$j = \frac{3}{2}l - 2 \quad \text{or} \quad 5 = \frac{3}{2} \times 5 - 2 = 5.5$$

i.e.

$$\text{L.H.S.} < \text{R.H.S.}$$

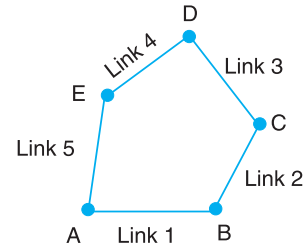

Fig. 5.8. Arrangement of five links.

Since the arrangement of five links, as shown in Fig. 5.8 does not satisfy the equations and left hand side is less than right hand side, therefore it is not a kinematic chain. Such a type of chain is called **unconstrained chain** i.e. the relative motion is not completely constrained. This type of chain is of little practical importance.

4. Consider an arrangement of six links, as shown in Fig. 5.9. This chain is formed by adding two more links in such a way that these two links form a pair with the existing links as well as form themselves a pair. In this case

$$l = 6, p = 5, \text{ and } j = 7$$

From equation (i),

$$l = 2p - 4 \quad \text{or} \quad 6 = 2 \times 5 - 4 = 6$$

i.e. L.H.S. = R.H.S.

From equation (ii),

$$j = \frac{3}{2}l - 2 \quad \text{or} \quad 7 = \frac{3}{2} \times 6 - 2 = 7$$

i.e. L.H.S. = R.H.S.

Since the arrangement of six links, as shown in Fig. 5.9, satisfies the equations (i.e. left hand side is equal to right hand side), therefore it is a kinematic chain.

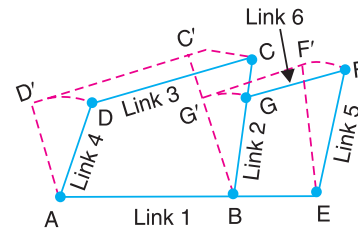

Fig. 5.9. Arrangement of six links.

Note : A chain having more than four links is known as **compound kinematic chain**.

5.10. Types of Joints in a Chain

The following types of joints are usually found in a chain :

1. Binary joint. When two links are joined at the same connection, the joint is known as binary joint. For example, a chain as shown in Fig. 5.10, has four links and four binary joints at A, B, C and D.

In order to determine the nature of chain, i.e. whether the chain is a locked chain (or structure) or kinematic chain or unconstrained chain, the following relation between the number of links and the number of binary joints, as given by A.W. Klein, may be used :

$$j + \frac{h}{2} = \frac{3}{2}l - 2 \quad \dots (i)$$

where

j = Number of binary joints,

h = Number of higher pairs, and

l = Number of links.

When $h = 0$, the equation (i), may be written as

$$j = \frac{3}{2}l - 2 \quad \dots (ii)$$

Applying this equation to a chain, as shown in Fig. 5.10, where $l = 4$ and $j = 4$, we have

$$4 = \frac{3}{2} \times 4 - 2 = 4$$

Since the left hand side is equal to the right hand side, therefore the chain is a kinematic chain or constrained chain.

2. Ternary joint. When three links are joined at the same connection, the joint is known as ternary joint. It is equivalent to two binary joints as one of the three links joined carry the pin for the other two links. For example, a chain, as shown in Fig. 5.11, has six links. It has three binary joints at A, B and D and two ternary joints at C and E. Since one ternary joint is equivalent to two binary joints, therefore equivalent binary joints in a chain, as shown in Fig. 5.11, are $3 + 2 \times 2 = 7$

Let us now determine whether this chain is a kinematic chain or not. We know that $l = 6$ and $j = 7$, therefore from

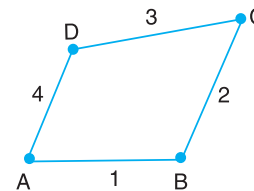

Fig. 5.10. Kinematic chain with all binary joints.

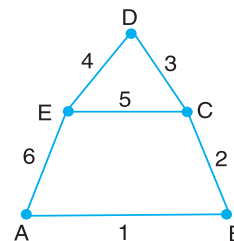

Fig. 5.11. Kinematic chain having binary and ternary joints.

equation (ii),

$$j = \frac{3}{2}l - 2$$

or

$$7 = \frac{3}{2} \times 6 - 2 = 7$$

Since left hand side is equal to right hand side, therefore the chain, as shown in Fig. 5.11, is a kinematic chain or constrained chain.

3. Quaternary joint. When four links are joined at the same connection, the joint is called a quaternary joint. It is equivalent to three binary joints. In general, when l number of links are joined at the same connection, the joint is equivalent to $(l - 1)$ binary joints.

For example consider a chain having eleven links, as shown in Fig. 5.12 (a). It has one binary joint at D , four ternary joints at A, B, E and F , and two quaternary joints at C and G . Since one quaternary joint is equivalent to three binary joints and one ternary joint is equal to two binary joints, therefore total number of binary joints in a chain, as shown in Fig. 5.12 (a), are

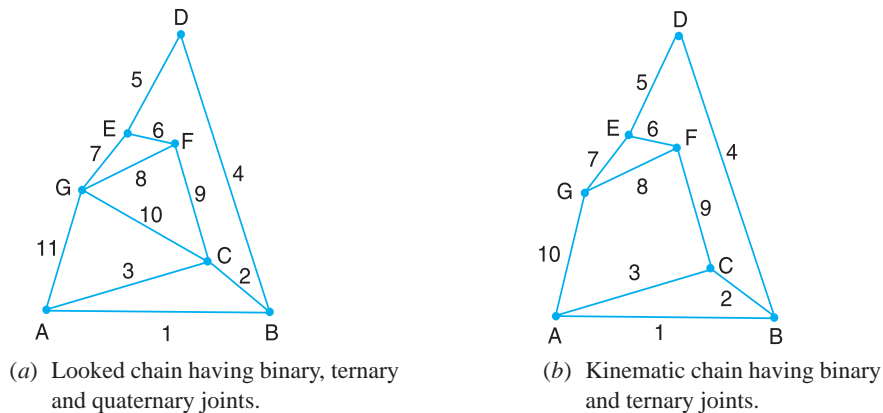

Fig. 5.12

$$1 + 4 \times 2 + 2 \times 3 = 15$$

Let us now determine whether the chain, as shown in Fig. 5.12 (a), is a kinematic chain or not. We know that $l = 11$ and $j = 15$. We know that,

$$j = \frac{3}{2}l - 2, \quad \text{or} \quad 15 = \frac{3}{2} \times 11 - 2 = 14.5, \quad \text{i.e., L.H.S.} > \text{R.H.S.}$$

Since the left hand side is greater than right hand side, therefore the chain, as shown in Fig. 5.12 (a), is not a kinematic chain. We have discussed in Art 5.9, that such a type of chain is called locked chain and forms a rigid frame or structure.

If the link CG is removed, as shown in Fig. 5.12 (b), it has ten links and has one binary joint at D and six ternary joints at A, B, C, E, F and G .

Therefore total number of binary joints are $1 + 2 \times 6 = 13$. We know that

$$j = \frac{3}{2}l - 2, \quad \text{or} \quad 13 = \frac{3}{2} \times 10 - 2 = 13, \quad \text{i.e., L.H.S.} = \text{R.H.S.}$$

Since left hand side is equal to right hand side, therefore the chain, as shown in Fig. 5.12 (b), is a kinematic chain or constrained chain.

5.11. Mechanism

When one of the links of a kinematic chain is fixed, the chain is known as **mechanism**. It may be used for transmitting or transforming motion e.g. engine indicators, typewriter etc.

A mechanism with four links is known as **simple mechanism**, and the mechanism with more than four links is known as **compound mechanism**. When a mechanism is required to transmit power or to do some particular type of work, it then becomes a **machine**. In such cases, the various links or elements have to be designed to withstand the forces (both static and kinetic) safely.

A little consideration will show that a mechanism may be regarded as a machine in which each part is reduced to the simplest form to transmit the required motion.

5.12. Number of Degrees of Freedom for Plane Mechanisms

In the design or analysis of a mechanism, one of the most important concern is the number of degrees of freedom (also called movability) of the mechanism. It is defined as the number of input parameters (usually pair variables) which must be independently controlled in order to bring the mechanism into a useful engineering purpose. It is possible to determine the number of degrees of freedom of a mechanism directly from the number of links and the number and types of joints which it includes.

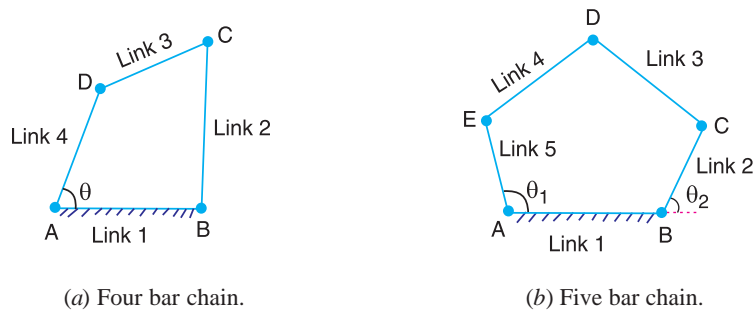

Fig. 5.13

Consider a four bar chain, as shown in Fig. 5.13 (a). A little consideration will show that only one variable such as θ is needed to define the relative positions of all the links. In other words, we say that the number of degrees of freedom of a four bar chain is one. Now, let us consider a five bar chain, as shown in Fig. 5.13 (b). In this case two variables such as θ_1 and θ_2 are needed to define completely the relative positions of all the links. Thus, we say that the number of degrees of freedom is * two.

In order to develop the relationship in general, consider two links AB and CD in a plane motion as shown in Fig. 5.14 (a).

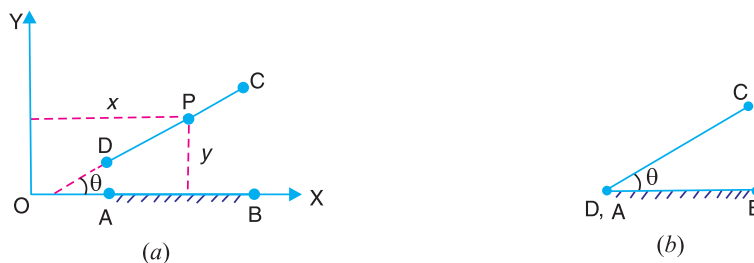

Fig. 5.14. Links in a plane motion.

The link AB with co-ordinate system OXY is taken as the reference link (or fixed link). The position of point P on the moving link CD can be completely specified by the three variables, *i.e.* the

* The differential of an automobile requires that the angular velocity of two elements be fixed in order to know the velocity of the remaining elements. The differential mechanism is thus said to have two degrees of freedom. Many computing mechanisms have two or more degrees of freedom.

co-ordinates of the point P denoted by x and y and the inclination θ of the link CD with X-axis or link AB . In other words, we can say that each link of a mechanism has three degrees of freedom before it is connected to any other link. But when the link CD is connected to the link AB by a turning pair at A , as shown in Fig. 5.14 (b), the position of link CD is now determined by a single variable θ and thus has one degree of freedom.

From above, we see that when a link is connected to a fixed link by a turning pair (*i.e.* lower pair), two degrees of freedom are destroyed. This may be clearly understood from Fig. 5.15, in which the resulting four bar mechanism has one degree of freedom (*i.e.* $n = 1$).

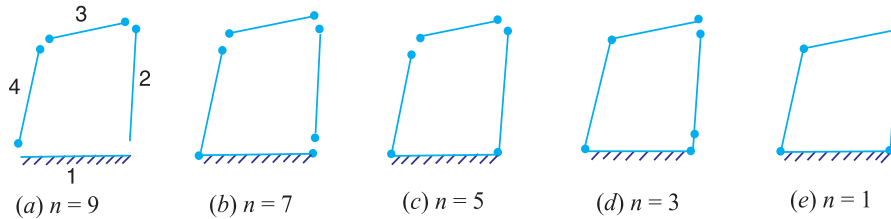

Fig. 5.15. Four bar mechanism.

Now let us consider a plane mechanism with l number of links. Since in a mechanism, one of the links is to be fixed, therefore the number of movable links will be $(l - 1)$ and thus the total number of degrees of freedom will be $3(l - 1)$ before they are connected to any other link. In general, a mechanism with l number of links connected by j number of binary joints or lower pairs (*i.e.* single degree of freedom pairs) and h number of higher pairs (*i.e.* two degree of freedom pairs), then the number of degrees of freedom of a mechanism is given by

$$n = 3(l - 1) - 2j - h \quad \dots (i)$$

This equation is called Kutzbach criterion for the movability of a mechanism having plane motion.

If there are no two degree of freedom pairs (*i.e.* higher pairs), then $h = 0$. Substituting $h = 0$ in equation (i), we have

$$n = 3(l - 1) - 2j \quad \dots (ii)$$

5.13. Application of Kutzbach Criterion to Plane Mechanisms

We have discussed in the previous article that Kutzbach criterion for determining the number of degrees of freedom or movability (n) of a plane mechanism is

$$n = 3(l - 1) - 2j - h$$

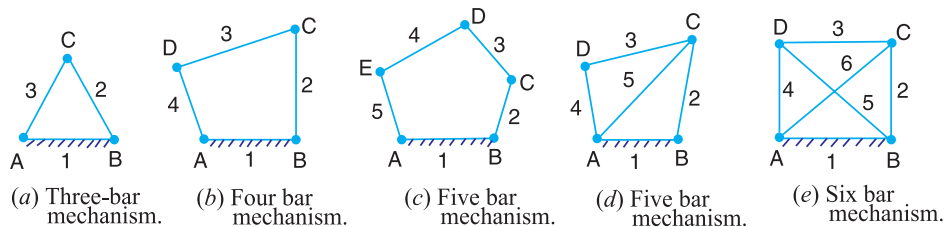

Fig. 5.16. Plane mechanisms.

The number of degrees of freedom or movability (n) for some simple mechanisms having no higher pair (*i.e.* $h = 0$), as shown in Fig. 5.16, are determined as follows :

1. The mechanism, as shown in Fig. 5.16 (a), has three links and three binary joints, *i.e.* $l = 3$ and $j = 3$.

$$\therefore n = 3(3 - 1) - 2 \times 3 = 0$$

2. The mechanism, as shown in Fig. 5.16 (b), has four links and four binary joints, *i.e.* $l = 4$ and $j = 4$.

$$\therefore n = 3(4 - 1) - 2 \times 4 = 1$$

3. The mechanism, as shown in Fig. 5.16 (c), has five links and five binary joints, *i.e.* $l = 5$, and $j = 5$.

$$\therefore n = 3(5 - 1) - 2 \times 5 = 2$$

4. The mechanism, as shown in Fig. 5.16 (d), has five links and six equivalent binary joints (because there are two binary joints at *B* and *D*, and two ternary joints at *A* and *C*), *i.e.* $l = 5$ and $j = 6$.

$$\therefore n = 3(5 - 1) - 2 \times 6 = 0$$

5. The mechanism, as shown in Fig. 5.16 (e), has six links and eight equivalent binary joints (because there are four ternary joints at *A*, *B*, *C* and *D*), *i.e.* $l = 6$ and $j = 8$.

$$\therefore n = 3(6 - 1) - 2 \times 8 = -1$$

It may be noted that

- (a) When $n = 0$, then the mechanism forms a structure and no relative motion between the links is possible, as shown in Fig. 5.16 (a) and (d).
- (b) When $n = 1$, then the mechanism can be driven by a single input motion, as shown in Fig. 5.16 (b).
- (c) When $n = 2$, then two separate input motions are necessary to produce constrained motion for the mechanism, as shown in Fig. 5.16 (c).
- (d) When $n = -1$ or less, then there are redundant constraints in the chain and it forms a statically indeterminate structure, as shown in Fig. 5.16 (e).

The application of Kutzbach's criterion applied to mechanisms with a higher pair or two degree of freedom joints is shown in Fig. 5.17.



Fig. 5.17. Mechanism with a higher pair.

In Fig. 5.17 (a), there are three links, two binary joints and one higher pair, *i.e.* $l = 3$, $j = 2$ and $h = 1$.

$$\therefore n = 3(3 - 1) - 2 \times 2 - 1 = 1$$

In Fig. 5.17 (b), there are four links, three binary joints and one higher pair, *i.e.* $l = 4$, $j = 3$ and $h = 1$

$$\therefore n = 3(4 - 1) - 2 \times 3 - 1 = 2$$

Here it has been assumed that the slipping is possible between the links (*i.e.* between the wheel and the fixed link). However if the friction at the contact is high enough to prevent slipping, the joint will be counted as one degree of freedom joint and only one relative motion will be possible between the links.

5.14. Grubler's Criterion for Plane Mechanisms

The Grubler's criterion applies to mechanisms with only single degree of freedom joints where the overall movability of the mechanism is unity. Substituting $n = 1$ and $h = 0$ in Kutzbach equation, we have

$$1 = 3(l - 1) - 2j \quad \text{or} \quad 3l - 2j - 4 = 0$$

This equation is known as the Grubler's criterion for plane mechanisms with constrained motion.

A little consideration will show that a plane mechanism with a movability of 1 and only single degree of freedom joints can not have odd number of links. The simplest possible mechanisms of this type are a four bar mechanism and a slider-crank mechanism in which $l = 4$ and $j = 4$.

5.15. Inversion of Mechanism

We have already discussed that when one of links is fixed in a kinematic chain, it is called a mechanism. So we can obtain as many mechanisms as the number of links in a kinematic chain by fixing, in turn, different links in a kinematic chain. This method of obtaining different mechanisms by fixing different links in a kinematic chain, is known as *inversion of the mechanism*.

It may be noted that the relative motions between the various links is not changed in any manner through the process of inversion, but their absolute motions (those measured with respect to the fixed link) may be changed drastically.

Note: The part of a mechanism which initially moves with respect to the frame or fixed link is called *driver* and that part of the mechanism to which motion is transmitted is called *follower*. Most of the mechanisms are reversible, so that same link can play the role of a driver and follower at different times. For example, in a reciprocating steam engine, the piston is the driver and flywheel is a follower while in a reciprocating air compressor, the flywheel is a driver.

5.16. Types of Kinematic Chains

The most important kinematic chains are those which consist of four lower pairs, each pair being a sliding pair or a turning pair. The following three types of kinematic chains with four lower pairs are important from the subject point of view :

1. Four bar chain or quadric cyclic chain,
2. Single slider crank chain, and
3. Double slider crank chain.

These kinematic chains are discussed, in detail, in the following articles.

5.17. Four Bar Chain or Quadric Cycle Chain

We have already discussed that the kinematic chain is a combination of four or more kinematic pairs, such that the relative motion between the links or elements is completely constrained. The simplest and the basic kinematic chain is a four bar chain or quadric cycle chain, as shown in Fig. 5.18. It consists of four links, each of them forms a turning pair at A , B , C and D . The four links may be of different lengths. According to **Grashof's law** for a four bar mechanism, the sum of the shortest and longest link lengths should not be greater than the sum of the remaining two link lengths if there is to be continuous relative motion between the two links.

A very important consideration in designing a mechanism is to ensure that the input crank makes a complete revolution.

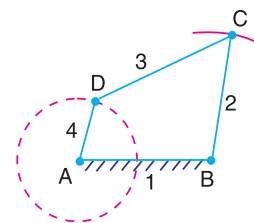

Fig. 5.18. Four bar chain.

other links. The mechanism in which no link makes a complete revolution will not be useful. In a four bar chain, one of the links, in particular the shortest link, will make a complete revolution relative to the other three links, if it satisfies the Grashof's law. Such a link is known as **crank** or **driver**. In Fig. 5.18, AD (link 4) is a crank. The link BC (link 2) which makes a partial rotation or oscillates is known as **lever** or **rocker** or **follower** and the link CD (link 3) which connects the crank and lever is called **connecting rod** or **coupler**. The fixed link AB (link 1) is known as **frame** of the mechanism.

When the crank (link 4) is the driver, the mechanism is transforming rotary motion into oscillating motion.

5.18. Inversions of Four Bar Chain

Though there are many inversions of the four bar chain, yet the following are important from the subject point of view :

1. Beam engine (crank and lever mechanism).

A part of the mechanism of a beam engine (also known as crank and lever mechanism) which consists of four links, is shown in Fig. 5.19. In this mechanism, when the crank rotates about the fixed centre A , the lever oscillates about a fixed centre D . The end E of the lever CDE is connected to a piston rod which reciprocates due to the rotation of the crank. In other words, the purpose of this mechanism is to convert rotary motion into reciprocating motion.

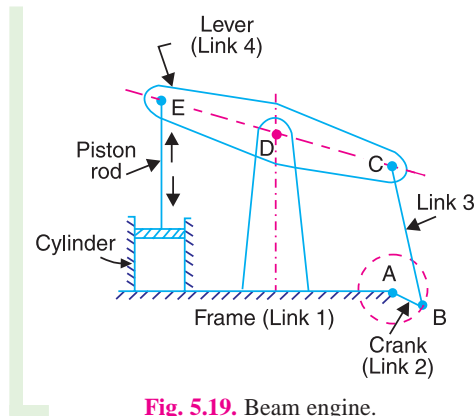
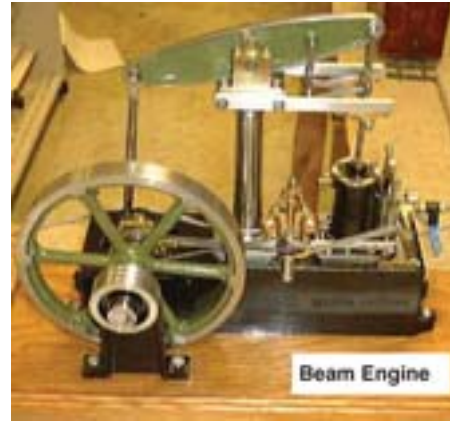

Fig. 5.19. Beam engine.

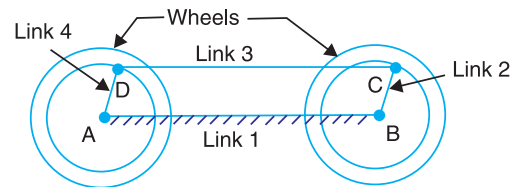

Fig. 5.20. Coupling rod of a locomotive.

2. Coupling rod of a locomotive (Double crank mechanism). The mechanism of a coupling rod of a locomotive (also known as double crank mechanism) which consists of four links, is shown in Fig. 5.20.

In this mechanism, the links AD and BC (having equal length) act as cranks and are connected to the respective wheels. The link CD acts as a coupling rod and the link AB is fixed in order to maintain a constant centre to centre distance between them. This mechanism is meant for transmitting rotary motion from one wheel to the other wheel.

3. Watt's indicator mechanism (Double lever mechanism). A *Watt's indicator mechanism (also known as Watt's straight line mechanism or double lever mechanism) which consists of four

links, is shown in Fig. 5.21. The four links are : fixed link at A, link AC, link CE and link BFD. It may be noted that BF and FD form one link because these two parts have no relative motion between them. The links CE and BFD act as levers. The displacement of the link BFD is directly proportional to the pressure of gas or steam which acts on the indicator plunger. On any small displacement of the mechanism, the tracing point E at the end of the link CE traces out approximately a straight line.

The initial position of the mechanism is shown in Fig. 5.21 by full lines whereas the dotted lines show the position of the mechanism when the gas or steam pressure acts on the indicator plunger.

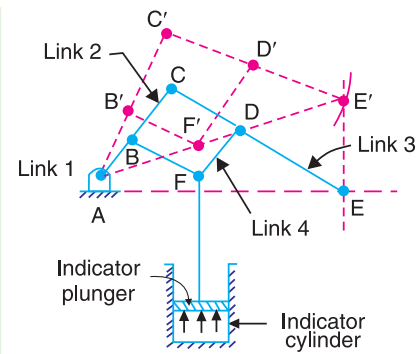

Fig. 5.21. Watt's indicator mechanism.

5.19. Single Slider Crank Chain

A single slider crank chain is a modification of the basic four bar chain. It consist of one sliding pair and three turning pairs. It is, usually, found in reciprocating steam engine mechanism. This type of mechanism converts rotary motion into reciprocating motion and vice versa.

In a single slider crank chain, as shown in Fig. 5.22, the links 1 and 2, links 2 and 3, and links 3 and 4 form three turning pairs while the links 4 and 1 form a sliding pair.

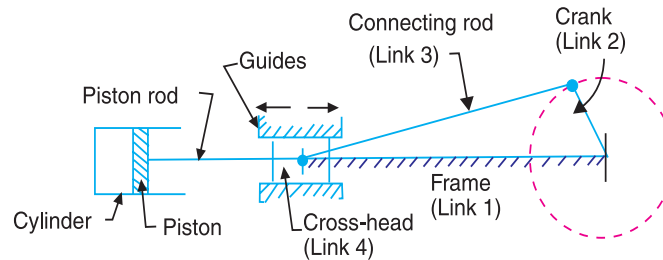

Fig. 5.22. Single slider crank chain.

The link 1 corresponds to the frame of the engine, which is fixed. The link 2 corresponds to the crank ; link 3 corresponds to the connecting rod and link 4 corresponds to cross-head. As the crank rotates, the cross-head reciprocates in the guides and thus the piston reciprocates in the cylinder.

5.20. Inversions of Single Slider Crank Chain

We have seen in the previous article that a single slider crank chain is a four-link mechanism. We know that by fixing, in turn, different links in a kinematic chain, an inversion is obtained and we can obtain as many mechanisms as the links in a kinematic chain. It is thus obvious, that four inversions of a single slider crank chain are possible. These inversions are found in the following mechanisms.

1. Pendulum pump or Bull engine. In this mechanism, the inversion is obtained by fixing the cylinder or link 4 (*i.e.* sliding pair), as shown in Fig. 5.23. In this case, when the crank (link 2) rotates, the connecting rod (link 3) oscillates about a pin pivoted to the fixed link 4 at A and the piston attached to the piston rod (link 1) reciprocates. The duplex pump which is used to supply feed water to boilers have two pistons attached to link 1, as shown in Fig. 5.23.

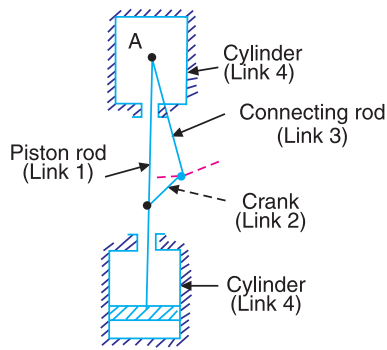

Fig. 5.23. Pendulum pump.

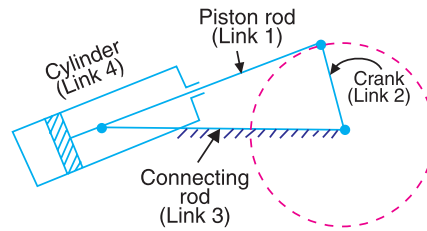

Fig. 5.24. Oscillating cylinder engine.

2. Oscillating cylinder engine. The arrangement of oscillating cylinder engine mechanism, as shown in Fig. 5.24, is used to convert reciprocating motion into rotary motion. In this mechanism, the link 3 forming the turning pair is fixed. The link 3 corresponds to the connecting rod of a reciprocating steam engine mechanism. When the crank (link 2) rotates, the piston attached to piston rod (link 1) reciprocates and the cylinder (link 4) oscillates about a pin pivoted to the fixed link at A.

3. Rotary internal combustion engine or Gnome engine. Sometimes back, rotary internal combustion engines were used in aviation. But now-a-days gas turbines are used in its place. It consists of seven cylinders in one plane and all revolves about fixed centre D, as shown in Fig. 5.25, while the crank (link 2) is fixed. In this mechanism, when the connecting rod (link 4) rotates, the piston (link 3) reciprocates inside the cylinders forming link 1.



Rotary engine

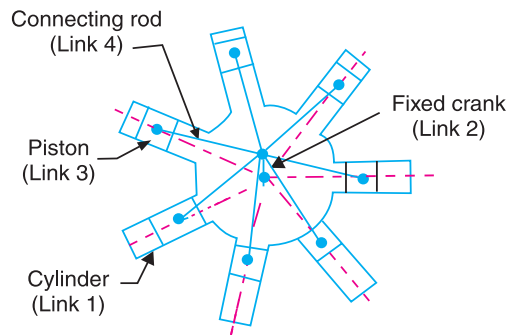

Fig. 5.25. Rotary internal combustion engine.

4. Crank and slotted lever quick return motion mechanism. This mechanism is mostly used in shaping machines, slotting machines and in rotary internal combustion engines.

In this mechanism, the link AC (*i.e.* link 3) forming the turning pair is fixed, as shown in Fig. 5.26. The link 3 corresponds to the connecting rod of a reciprocating steam engine. The driving crank CB revolves with uniform angular speed about the fixed centre C . A sliding block attached to the crank pin at B slides along the slotted bar AP and thus causes AP to oscillate about the pivoted point A . A short link PR transmits the motion from AP to the ram which carries the tool and reciprocates along the line of stroke R_1R_2 . The line of stroke of the ram (*i.e.* R_1R_2) is perpendicular to AC produced.

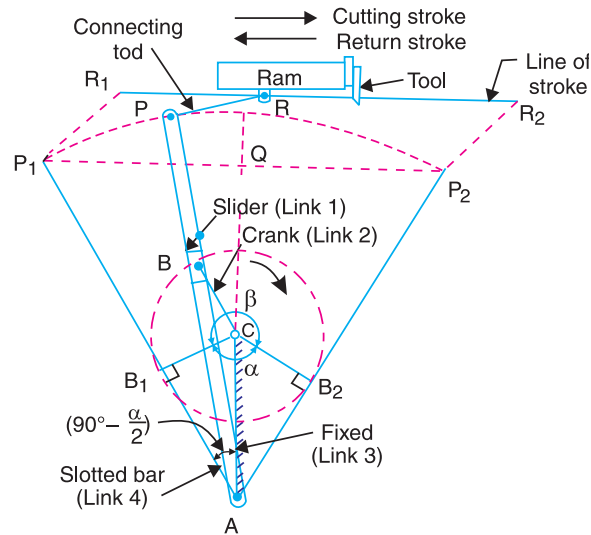

Fig. 5.26. Crank and slotted lever quick return motion mechanism.

In the extreme positions, AP_1 and AP_2 are tangential to the circle and the cutting tool is at the end of the stroke. The forward or cutting stroke occurs when the crank rotates from the position CB_1 to CB_2 (or through an angle β) in the clockwise direction. The return stroke occurs when the crank rotates from the position CB_2 to CB_1 (or through angle α) in the clockwise direction. Since the crank has uniform angular speed, therefore,

$$\frac{\text{Time of cutting stroke}}{\text{Time of return stroke}} = \frac{\beta}{\alpha} = \frac{\beta}{360^\circ - \beta} \quad \text{or} \quad \frac{360^\circ - \alpha}{\alpha}$$

Since the tool travels a distance of R_1R_2 during cutting and return stroke, therefore travel of the tool or length of stroke

$$\begin{aligned} &= R_1R_2 = P_1P_2 = 2P_1Q = 2AP_1 \sin \angle P_1AQ \\ &= 2AP_1 \sin \left(90^\circ - \frac{\alpha}{2}\right) = 2AP \cos \frac{\alpha}{2} \quad \dots (\because AP_1 = AP) \\ &= 2AP \times \frac{CB_1}{AC} \quad \dots \left(\because \cos \frac{\alpha}{2} = \frac{CB_1}{AC}\right) \\ &= 2AP \times \frac{CB}{AC} \quad \dots (\because CB_1 = CB) \end{aligned}$$

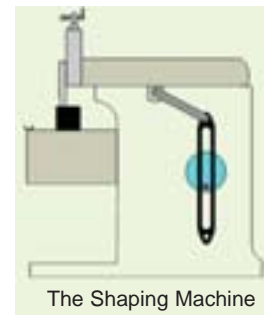

Note: From Fig. 5.26, we see that the angle β made by the forward or cutting stroke is greater than the angle α described by the return stroke. Since the crank rotates with uniform angular speed, therefore the return stroke is completed within shorter time. Thus it is called quick return motion mechanism.

5. Whitworth quick return motion mechanism. This mechanism is mostly used in shaping and slotting machines. In this mechanism, the link CD (link 2) forming the turning pair is fixed, as shown in Fig. 5.27. The link 2 corresponds to a crank in a reciprocating steam engine. The driving crank CA (link 3) rotates at a uniform angular speed. The slider (link 4) attached to the crank pin at A slides along the slotted bar PA (link 1) which oscillates at a pivoted point D . The connecting rod PR carries the ram at R to which a cutting tool is fixed. The motion of the tool is constrained along the line RD produced, *i.e.* along a line passing through D and perpendicular to CD .

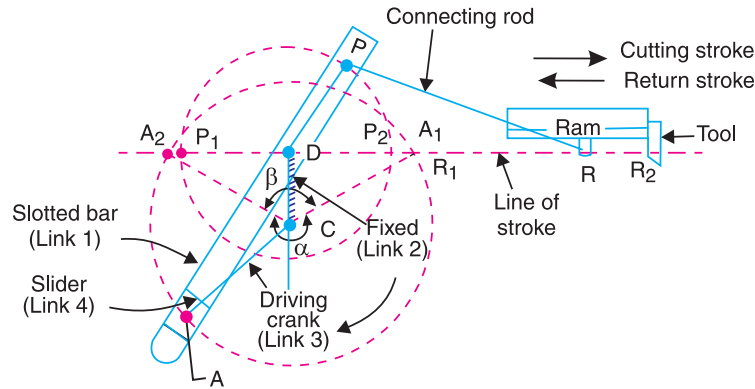

Fig. 5.27. Whitworth quick return motion mechanism.

When the driving crank CA moves from the position CA_1 to CA_2 (or the link DP from the position DP_1 to DP_2) through an angle α in the clockwise direction, the tool moves from the left hand end of its stroke to the right hand end through a distance $2 PD$.

Now when the driving crank moves from the position CA_2 to CA_1 (or the link DP from DP_2 to DP_1) through an angle β in the clockwise direction, the tool moves back from right hand end of its stroke to the left hand end.

A little consideration will show that the time taken during the left to right movement of the ram (*i.e.* during forward or cutting stroke) will be equal to the time taken by the driving crank to move from CA_1 to CA_2 . Similarly, the time taken during the right to left movement of the ram (or during the idle or return stroke) will be equal to the time taken by the driving crank to move from CA_2 to CA_1 .

Since the crank link CA rotates at uniform angular velocity therefore time taken during the cutting stroke (or forward stroke) is more than the time taken during the return stroke. In other words, the mean speed of the ram during cutting stroke is less than the mean speed during the return stroke. The ratio between the time taken during the cutting and return strokes is given by

$$\frac{\text{Time of cutting stroke}}{\text{Time of return stroke}} = \frac{\alpha}{\beta} = \frac{\alpha}{360^\circ - \alpha} \quad \text{or} \quad \frac{360^\circ - \beta}{\beta}$$

Note. In order to find the length of effective stroke $R_1 R_2$, mark $P_1 R_1 = P_2 R_2 = PR$. The length of effective stroke is also equal to $2 PD$.

Example 5.1. A crank and slotted lever mechanism used in a shaper has a centre distance of 300 mm between the centre of oscillation of the slotted lever and the centre of rotation of the crank. The radius of the crank is 120 mm. Find the ratio of the time of cutting to the time of return stroke.

Solution. Given : $AC = 300$ mm ; $CB_1 = 120$ mm

The extreme positions of the crank are shown in Fig. 5.28. We know that

$$\begin{aligned}\sin \angle CAB_1 &= \sin(90^\circ - \alpha/2) \\ &= \frac{CB_1}{AC} = \frac{120}{300} = 0.4\end{aligned}$$

$$\begin{aligned}\therefore \angle CAB_1 &= 90^\circ - \alpha/2 \\ &= \sin^{-1} 0.4 = 23.6^\circ \\ \alpha/2 &= 90^\circ - 23.6^\circ = 66.4^\circ \\ \alpha &= 2 \times 66.4 = 132.8^\circ\end{aligned}$$

or
and

We know that

$$\frac{\text{Time of cutting stroke}}{\text{Time of return stroke}} = \frac{360^\circ - \alpha}{\alpha} = \frac{360^\circ - 132.8^\circ}{132.8^\circ} = 1.72 \text{ Ans.}$$

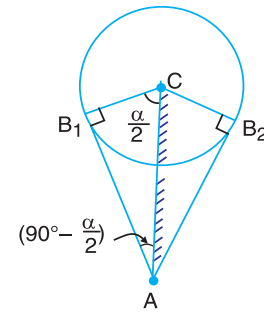

Fig. 5.28

Example 5.2. In a crank and slotted lever quick return motion mechanism, the distance between the fixed centres is 240 mm and the length of the driving crank is 120 mm. Find the inclination of the slotted bar with the vertical in the extreme position and the time ratio of cutting stroke to the return stroke.

If the length of the slotted bar is 450 mm, find the length of the stroke if the line of stroke passes through the extreme positions of the free end of the lever.

Solution. Given : $AC = 240$ mm ; $CB_1 = 120$ mm ; $AP_1 = 450$ mm

Inclination of the slotted bar with the vertical

Let $\angle CAB_1 =$ Inclination of the slotted bar with the vertical.

The extreme positions of the crank are shown in Fig. 5.29. We know that

$$\begin{aligned}\sin \angle CAB_1 &= \sin\left(90^\circ - \frac{\alpha}{2}\right) \\ &= \frac{B_1C}{AC} = \frac{120}{240} = 0.5 \\ \therefore \angle CAB_1 &= 90^\circ - \frac{\alpha}{2} \\ &= \sin^{-1} 0.5 = 30^\circ \text{ Ans.}\end{aligned}$$

Time ratio of cutting stroke to the return stroke

We know that

$$90^\circ - \alpha/2 = 30^\circ$$

$$\therefore \alpha/2 = 90^\circ - 30^\circ = 60^\circ$$

or

$$\alpha = 2 \times 60^\circ = 120^\circ$$

$$\therefore \frac{\text{Time of cutting stroke}}{\text{Time of return stroke}} = \frac{360^\circ - \alpha}{\alpha} = \frac{360^\circ - 120^\circ}{120^\circ} = 2 \text{ Ans.}$$

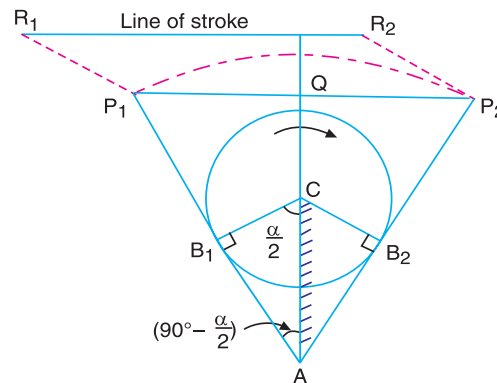

Fig. 5.29

Length of the stroke

We know that length of the stroke,

$$\begin{aligned} R_1R_2 &= P_1P_2 = 2 P_1Q = 2 AP_1 \sin (90^\circ - \alpha / 2) \\ &= 2 \times 450 \sin (90^\circ - 60^\circ) = 900 \times 0.5 = 450 \text{ mm Ans.} \end{aligned}$$

Example 5.3. Fig. 5.30 shows the lay out of a quick return mechanism of the oscillating link type, for a special purpose machine. The driving crank BC is 30 mm long and time ratio of the working stroke to the return stroke is to be 1.7. If the length of the working stroke of R is 120 mm, determine the dimensions of AC and AP.

Solution. Given : $BC = 30 \text{ mm}$; $R_1R_2 = 120 \text{ mm}$; Time ratio of working stroke to the return stroke = 1.7

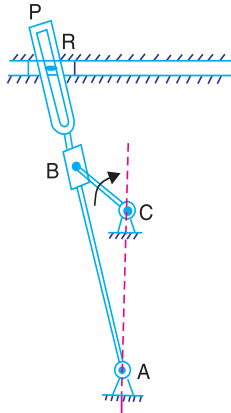

Fig. 5.30

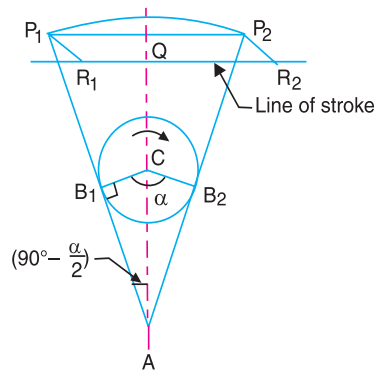

Fig. 5.31

We know that

$$\begin{aligned} \frac{\text{Time of working stroke}}{\text{Time of return stroke}} &= \frac{360 - \alpha}{\alpha} \quad \text{or} \quad 1.7 = \frac{360 - \alpha}{\alpha} \\ \therefore \quad \alpha &= 133.3^\circ \quad \text{or} \quad \alpha / 2 = 66.65^\circ \end{aligned}$$

The extreme positions of the crank are shown in Fig. 5.31. From right angled triangle $A B_1C$, we find that

$$\begin{aligned} \sin (90^\circ - \alpha/2) &= \frac{B_1C}{AC} \quad \text{or} \quad AC = \frac{B_1C}{\sin (90^\circ - \alpha/2)} = \frac{BC}{\cos \alpha/2} \\ &\dots (\because B_1C = BC) \end{aligned}$$

$$\therefore \quad AC = \frac{30}{\cos 66.65^\circ} = \frac{30}{0.3963} = 75.7 \text{ mm Ans.}$$

We know that length of stroke,

$$\begin{aligned} R_1R_2 &= P_1P_2 = 2 P_1Q = 2 AP_1 \sin (90^\circ - \alpha / 2) = 2 AP_1 \cos \alpha / 2 \\ 120 &= 2 AP \cos 66.65^\circ = 0.7926 AP \quad \dots (\because AP_1 = AP) \end{aligned}$$

$$\therefore \quad AP = 120 / 0.7926 = 151.4 \text{ mm Ans.}$$

Example 5.4. In a Whitworth quick return motion mechanism, as shown in Fig. 5.32, the distance between the fixed centers is 50 mm and the length of the driving crank is 75 mm. The length of the slotted lever is 150 mm and the length of the connecting rod is 135 mm. Find the ratio of the time of cutting stroke to the time of return stroke and also the effective stroke.

Solution. Given : $CD = 50 \text{ mm}$; $CA = 75 \text{ mm}$; $PA = 150 \text{ mm}$; $PR = 135 \text{ mm}$

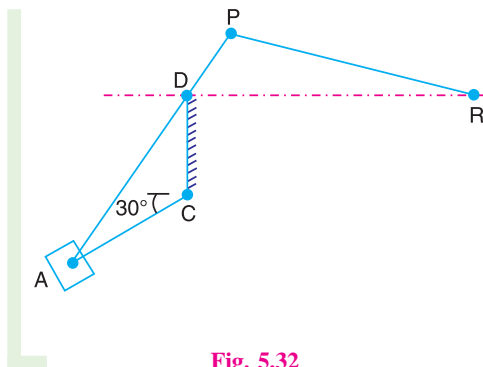

Fig. 5.32

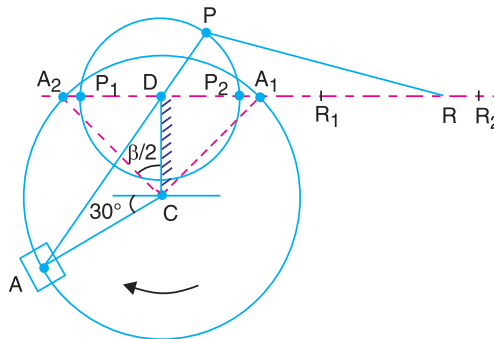

Fig. 5.33

The extreme positions of the driving crank are shown in Fig. 5.33. From the geometry of the figure,

$$\cos \beta/2 = \frac{CD}{CA_2} = \frac{50}{75} = 0.667 \quad \dots (\because CA_2 = CA)$$

$$\therefore \beta/2 = 48.2^\circ \quad \text{or} \quad \beta = 96.4^\circ$$

Ratio of the time of cutting stroke to the time of return stroke

We know that

$$\frac{\text{Time of cutting stroke}}{\text{Time of return stroke}} = \frac{360 - \beta}{\beta} = \frac{360 - 96.4}{96.4} = 2.735 \quad \text{Ans.}$$

Length of effective stroke

In order to find the length of effective stroke (*i.e.* R_1R_2), draw the space diagram of the mechanism to some suitable scale, as shown in Fig. 5.33. Mark $P_1R_2 = P_2R_2 = PR$. Therefore by measurement we find that,

$$\text{Length of effective stroke} = R_1R_2 = 87.5 \text{ mm} \quad \text{Ans.}$$

5.21. Double Slider Crank Chain

A kinematic chain which consists of two turning pairs and two sliding pairs is known as **double slider crank chain**, as shown in Fig. 5.34. We see that the link 2 and link 1 form one turning pair and link 2 and link 3 form the second turning pair. The link 3 and link 4 form one sliding pair and link 1 and link 4 form the second sliding pair.

5.22. Inversions of Double Slider Crank Chain

The following three inversions of a double slider crank chain are important from the subject point of view :

1. Elliptical trammels. It is an instrument used for drawing ellipses. This inversion is obtained by fixing the slotted plate (link 4), as shown in Fig. 5.34. The fixed plate or link 4 has two straight grooves cut in it, at right angles to each other. The link 1 and link 3, are known as sliders and form sliding pairs with link 4. The link AB (link 2) is a bar which forms turning pair with links 1 and 3.

When the links 1 and 3 slide along their respective grooves, any point on the link 2 such as P traces out an ellipse on the surface of link 4, as shown in Fig. 5.34 (a). A little consideration will show that AP and BP are the semi-major axis and semi-minor axis of the ellipse respectively. This can be proved as follows :

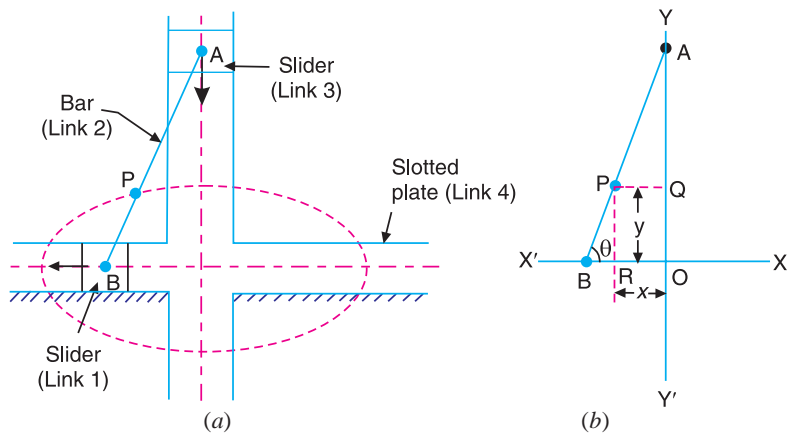

Fig. 5.34. Elliptical trammels.

Let us take OX and OY as horizontal and vertical axes and let the link BA be inclined at an angle θ with the horizontal, as shown in Fig. 5.34 (b). Now the co-ordinates of the point P on the link BA will be

$$x = PQ = AP \cos \theta; \text{ and } y = PR = BP \sin \theta$$

or
$$\frac{x}{AP} = \cos \theta; \text{ and } \frac{y}{BP} = \sin \theta$$

Squaring and adding,

$$\frac{x^2}{(AP)^2} + \frac{y^2}{(BP)^2} = \cos^2 \theta + \sin^2 \theta = 1$$

This is the equation of an ellipse. Hence the path traced by point P is an ellipse whose semi-major axis is AP and semi-minor axis is BP .

Note : If P is the mid-point of link BA , then $AP = BP$. The above equation can be written as

$$\frac{x^2}{(AP)^2} + \frac{y^2}{(AP)^2} = 1 \quad \text{or} \quad x^2 + y^2 = (AP)^2$$

This is the equation of a circle whose radius is AP . Hence if P is the mid-point of link BA , it will trace a circle.

2. Scotch yoke mechanism. This mechanism is used for converting rotary motion into a reciprocating motion. The inversion is obtained by fixing either the link 1 or link 3. In Fig. 5.35, link 1 is fixed. In this mechanism, when the link 2 (which corresponds to crank) rotates about B as centre, the link 4 (which corresponds to a frame) reciprocates. The fixed link 1 guides the frame.

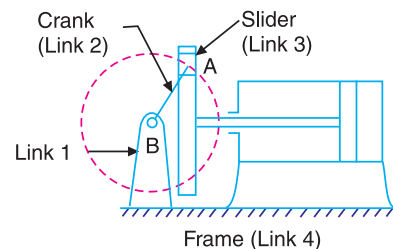

Fig. 5.35. Scotch yoke mechanism.

3. Oldham's coupling. An oldham's coupling is used for connecting two parallel shafts whose axes are at a small distance apart. The shafts are coupled in such a way that if one shaft rotates, the other shaft also rotates at the same speed. This inversion is obtained by fixing the link 2, as shown in Fig. 5.36 (a). The shafts to be connected have two flanges (link 1 and link 3) rigidly fastened at their ends by forging.

The link 1 and link 3 form turning pairs with link 2. These flanges have diametrical slots cut in their inner faces, as shown in Fig. 5.36 (b). The intermediate piece (link 4) which is a circular disc, have two tongues (*i.e.* diametrical projections) T_1 and T_2 on each face at right angles to each other, as shown in Fig. 5.36 (c). The tongues on the link 4 closely fit into the slots in the two flanges (link 1 and link 3). The link 4 can slide or reciprocate in the slots in the flanges.

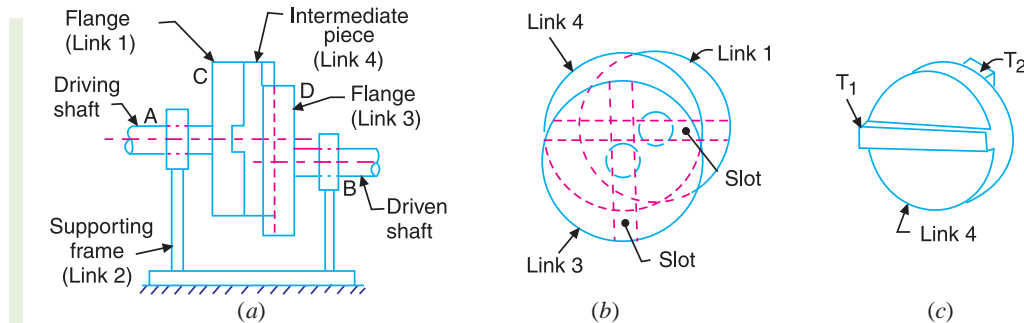

Fig. 5.36. Oldham's coupling.

When the driving shaft A is rotated, the flange C (link 1) causes the intermediate piece (link 4) to rotate at the same angle through which the flange has rotated, and it further rotates the flange D (link 3) at the same angle and thus the shaft B rotates. Hence links 1, 3 and 4 have the same angular velocity at every instant. A little consideration will show, that there is a sliding motion between the link 4 and each of the other links 1 and 3.

If the distance between the axes of the shafts is constant, the centre of intermediate piece will describe a circle of radius equal to the distance between the axes of the two shafts. Therefore, the maximum sliding speed of each tongue along its slot is equal to the peripheral velocity of the centre of the disc along its circular path.

Let ω = Angular velocity of each shaft in rad/s, and

r = Distance between the axes of the shafts in metres.

\therefore Maximum sliding speed of each tongue (in m/s),

$$v = \omega.r$$

EXERCISES

- In a crank and slotted lever quick return mechanism, the distance between the fixed centres is 150 mm and the driving crank is 75 mm long. Determine the ratio of the time taken on the cutting and return strokes. [Ans. 2]
- In a crank and slotted lever quick return motion mechanism, the distance between the fixed centres O and C is 200 mm. The driving crank CP is 75 mm long. The pin Q on the slotted lever, 360 mm from the fulcrum O , is connected by a link QR 100 mm long, to a pin R on the ram. The line of stroke of R is perpendicular to OC and intersects OC produced at a point 150 mm from C . Determine the ratio of times taken on the cutting and return strokes. [Ans. 1.647]
- In a crank and slotted lever quick return mechanism, as shown in Fig. 5.37, the driving crank length is 75 mm. The distance between the fixed centres is 200 mm and the length of the slotted lever is 500 mm. Find the ratio of the times taken on the cutting and idle strokes. Determine the effective stroke also. [Ans. 1.67 ; 380 mm]

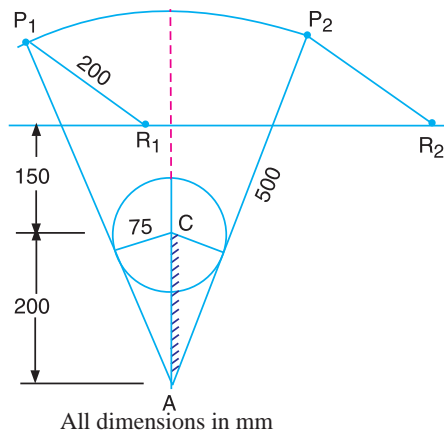

Fig. 5.37

4. The Whitworth quick return motion mechanism has the driving crank 150 mm long. The distance between fixed centres is 100 mm. The line of stroke of the ram passes through the centre of rotation of the slotted lever whose free end is connected to the ram by a connecting link. Find the ratio of time of cutting to time of return. **[Ans. 2.735]**
5. A Whitworth quick return motion mechanism, as shown in Fig. 5.38, has the following particulars :

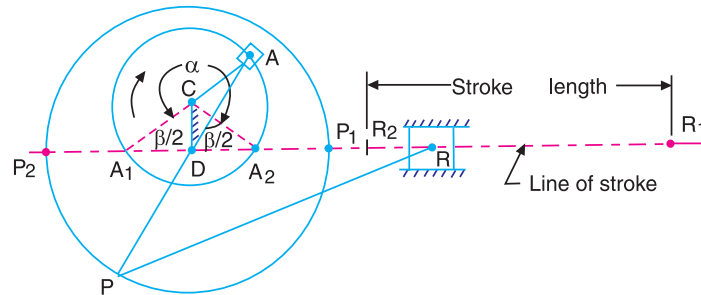

Fig. 5.38

Length of stroke = 150 mm ; Driving crank length = 40 mm; $\frac{\text{Time of cutting stroke}}{\text{Time of return stroke}} = 2$

Find the lengths of CD and PD . Also determine the angles α and β .

[Hint : Length of stroke = $R_1R_2 = P_1P_2 = 2PD$]

[Ans. 20 mm, 75 mm; 240° , 120°]

DO YOU KNOW ?

1. Explain the term kinematic link. Give the classification of kinematic link.
2. What is a machine ? Giving example, differentiate between a machine and a structure.
3. Write notes on complete and incomplete constraints in lower and higher pairs, illustrating your answer with neat sketches.
4. Explain different kinds of kinematic pairs giving example for each one of them.
5. Explain the terms : 1. Lower pair, 2. Higher pair, 3. Kinematic chain, and 4. Inversion.
6. In what way a mechanism differ from a machine ?
7. What is the significance of degrees of freedom of a kinematic chain when it functions as a mechanism? Give examples.

8. Determine the mobility (degrees of freedom) of the mechanism shown in Fig. 5.39 (a) and (b) using Kutzbach mobility criterion and classify them.

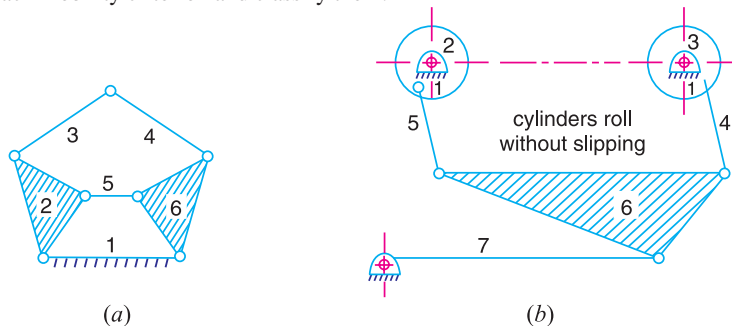

Fig. 5.39

9. Explain Grubler's criterion for determining degree of freedom for mechanisms. Using Grubler's criterion for plane mechanism, prove that the minimum number of binary links in a constrained mechanism with simple hinges is four.
10. Sketch and explain the various inversions of a slider crank chain.
11. Sketch and describe the four bar chain mechanism. Why it is considered to be the basic chain?
12. Show that slider crank mechanism is a modification of the basic four bar mechanism.
13. Sketch slider crank chain and its various inversions, stating actual machines in which these are used in practice.
14. Sketch and describe the working of two different types of quick return mechanisms. Give examples of their applications. Derive an expression for the ratio of times taken in forward and return stroke for one of these mechanisms.
15. Sketch and explain any two inversions of a double slider crank chain.
16. Identify the kinematic chains to which the following mechanisms belong :
1. Steam engine mechanism ; 2. Beam engine ; 3. Whitworth quick return motion mechanism;
 4. Elliptical trammels.

OBJECTIVE TYPE QUESTIONS

1. In a reciprocating steam engine, which of the following forms a kinematic link ?

(a) cylinder and piston	(b) piston rod and connecting rod
(c) crank shaft and flywheel	(d) flywheel and engine frame
2. The motion of a piston in the cylinder of a steam engine is an example of

(a) completely constrained motion	(b) incompletely constrained motion
(c) successfully constrained motion	(d) none of these
3. The motion transmitted between the teeth of gears in mesh is

(a) sliding	(b) rolling
(c) may be rolling or sliding depending upon the shape of teeth	(d) partly sliding and partly rolling
4. The cam and follower without a spring forms a

(a) lower pair	(b) higher pair
(c) self closed pair	(d) force closed pair
5. A ball and a socket joint forms a

(a) turning pair	(b) rolling pair	(c) sliding pair	(d) spherical pair
------------------	------------------	------------------	--------------------
6. The lead screw of a lathe with nut forms a

(a) sliding pair	(b) rolling pair	(c) screw pair	(d) turning pair
------------------	------------------	----------------	------------------
7. When the elements of the pair are kept in contact by the action of external forces, the pair is said to be a

(a) lower pair	(b) higher pair
(c) self closed pair	(d) force closed pair

8. Which of the following is a turning pair ?
 (a) Piston and cylinder of a reciprocating steam engine
 (b) Shaft with collars at both ends fitted in a circular hole
 (c) Lead screw of a lathe with nut
 (d) Ball and socket joint
9. A combination of kinematic pairs, joined in such a way that the relative motion between the links is completely constrained, is called a
 (a) structure (b) mechanism
 (c) kinematic chain (d) inversion
10. The relation between the number of pairs (p) forming a kinematic chain and the number of links (l) is
 (a) $l = 2p - 2$ (b) $l = 2p - 3$ (c) $l = 2p - 4$ (d) $l = 2p - 5$
11. The relation between the number of links (l) and the number of binary joints (j) for a kinematic chain having constrained motion is given by $j = \frac{3}{2}l - 2$. If the left hand side of this equation is greater than right hand side, then the chain is
 (a) locked chain (b) completely constrained chain
 (c) successfully constrained chain (d) incompletely constrained chain
12. In a kinematic chain, a quaternary joint is equivalent to
 (a) one binary joint (b) two binary joints (c) three binary joints (d) four binary joints
13. If n links are connected at the same joint, the joint is equivalent to
 (a) $(n - 1)$ binary joints (b) $(n - 2)$ binary joints (c) $(2n - 1)$ binary joints (d) none of these
14. In a 4 - bar linkage, if the lengths of shortest, longest and the other two links are denoted by s, l, p and q , then it would result in Grashof's linkage provided that
 (a) $l + p < s + q$ (b) $l + s < p + q$ (c) $l + p = s + q$ (d) none of these
15. A kinematic chain is known as a mechanism when
 (a) none of the links is fixed (b) one of the links is fixed
 (c) two of the links are fixed (d) all of the links are fixed
16. The Grubler's criterion for determining the degrees of freedom (n) of a mechanism having plane motion is
 (a) $n = (l - 1) - j$ (b) $n = 2(l - 1) - 2j$ (c) $n = 3(l - 1) - 2j$ (d) $n = 4(l - 1) - 3j$
 where l = Number of links, and j = Number of binary joints.
17. The mechanism forms a structure, when the number of degrees of freedom (n) is equal to
 (a) 0 (b) 1 (c) 2 (d) - 1
18. In a four bar chain or quadric cycle chain
 (a) each of the four pairs is a turning pair (b) one is a turning pair and three are sliding pairs
 (c) three are turning pairs and one is sliding pair (d) each of the four pairs is a sliding pair.
19. Which of the following is an inversion of single slider crank chain ?
 (a) Beam engine (b) Watt's indicator mechanism
 (c) Elliptical trammels (d) Whitworth quick return motion mechanism
20. Which of the following is an inversion of double slider crank chain ?
 (a) Coupling rod of a locomotive (b) Pendulum pump
 (c) Elliptical trammels (d) Oscillating cylinder engine

ANSWERS

- | | | | | |
|---------|---------|---------|---------|---------|
| 1. (c) | 2. (a) | 3. (d) | 4. (c) | 5. (d) |
| 6. (c) | 7. (d) | 8. (b) | 9. (c) | 10. (c) |
| 11. (a) | 12. (c) | 13. (a) | 14. (b) | 15. (b) |
| 16. (c) | 17. (a) | 18. (a) | 19. (d) | 20. (c) |